



159-208
SWT 64

ALUSYSTEMS

Aluminyum Kapı Pencere ve Giydirme Cephe Sistemleri
Aluminium Window Doors and Facade Systems



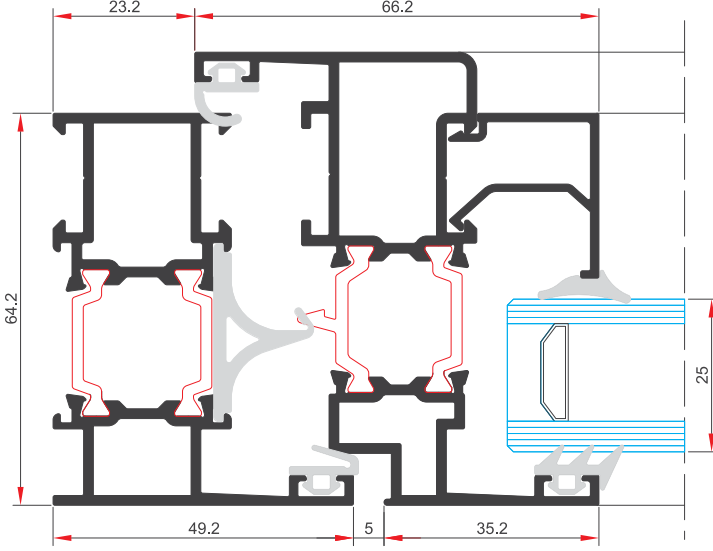

TEKNİK DETAYLAR | TECHNICAL DETAILS

	KASA GENİRLİĞİ : 64.2 MM FRAME WIDTH : 64.2 MM		ISI BARIYERİ : 14.8 MM HEAT BARRIER : 14.8 MM
	ET KALINLIĞI : 1.3 MM - 1.5 MM - 1.6 MM - 1.8 MM - 2 MM WALL THICKNESS : 1.2 MM - 1.5 MM - 1.6 MM - 1.8 MM - 2 MM		CAM KALINLIĞI : 13 MM ~ 41 MM GLASS THICKNESS : 13 MM ~ 41 MM
	AKSESUAR KANAL TİPİ : ACCESSORY CHANNEL TYPE :	EUROGROOVE 1 KANALA UYGUN - PVC KANAL (9 AKS) UYGUN KANATLAR EUROGROOVE SUITABLE FOR 1 CHANNEL - PVC (9 AXLES) SUITABLE WINGS	
	AÇILIM ÇEŞİTLERİ : EXPANSION TYPES :	TEK AÇILIM PENCERE, ÇİFT AÇILIM PENCERE, İÇE AÇILIR TEK KANAT KAPI, İÇE AÇILIR ÇİFT KANAT KAPI, PARALEL SÜRME, DIŞA AÇILIM KAPI SINGLE OPENING WINDOW, DOUBLE OPENING WINDOW, INWARD OPENING SINGLE WING DOOR, INWARD OPENING DOUBLE WING DOOR, PARALLEL SLIDING, OUTWARD OPENING DOOR	
	ISI GEÇİRGENLİK KAT SAYISI (Uf) : 2.65 W/m ² .K HEAT CONDUCTIVITY COEFFICIENT (Uf) : 2.65 W/m ² .K		

ALUSYSTEMS

Aluminyum Kapı Pencere ve Giydirme Cephe Sistemleri
Aluminium Window Doors and Facade Systems



MİMARİ KATALOG

ARCHITECTURAL CATALOGUE

Aluminyum Kapı Pencere ve Giydirme Cephe Sistemleri
Aluminium Window Doors and Facade Systems



ALUSYSTEMS
Profil Detayları

ALUSYSTEMS
Profile Details

SWT 64

PROFİLLER
PROFILES



ALUSYSTEMS

Aluminyum Kapı Pencere ve Giydirme Cephe Sistemleri
Aluminium Window Doors and Facade Systems



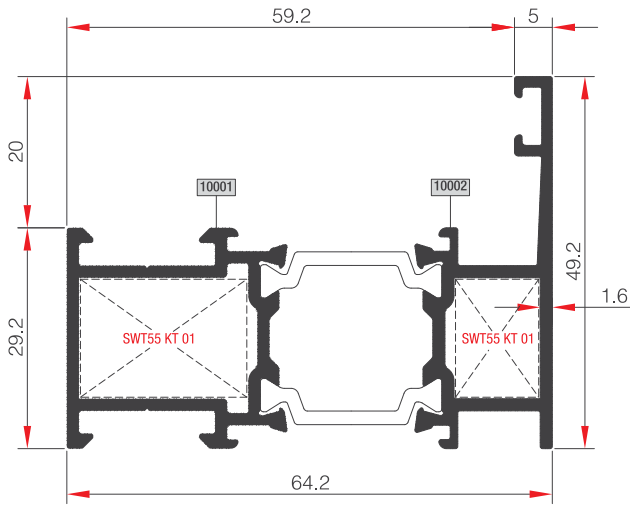

SWT64 KS 01

AĞIRLIK (kg/m) / WEIGHT kg/m	1.264
Jx (cm ⁴)	21.388
Jy (cm ⁴)	5.639

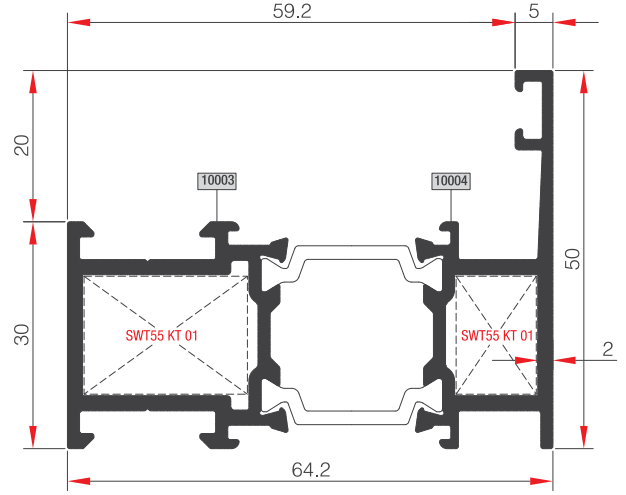

SWT64 KS 02

AĞIRLIK (kg/m) / WEIGHT kg/m	1.389
Jx (cm ⁴)	24.293
Jy (cm ⁴)	6.227

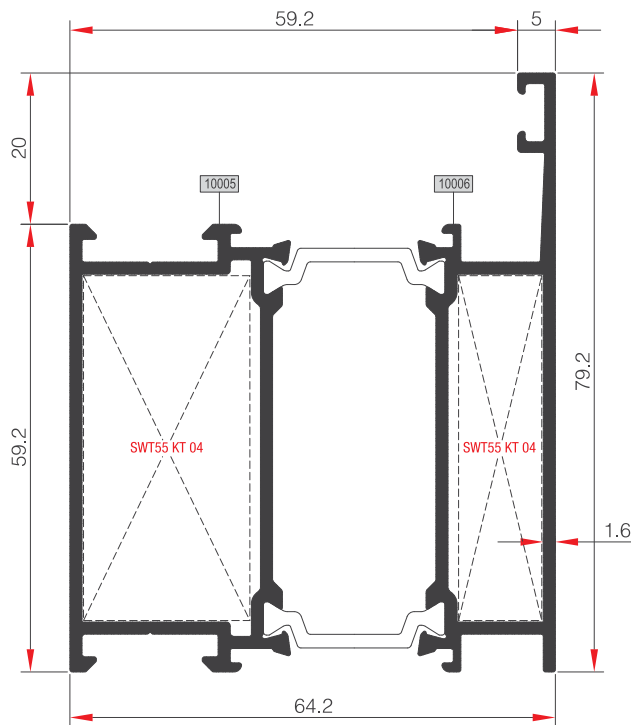

SWT64 KS 03

AĞIRLIK (kg/m) / WEIGHT kg/m	1.782
Jx (cm ⁴)	32.236
Jy (cm ⁴)	28.504

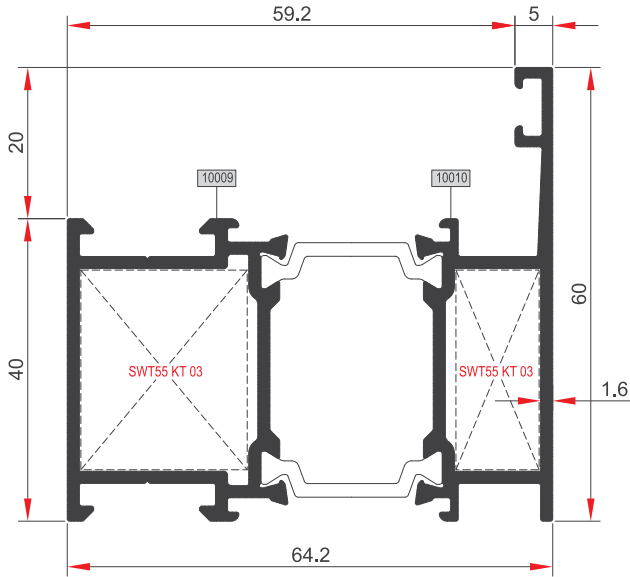

SWT64 KS 05

AĞIRLIK (kg/m) / WEIGHT kg/m	1.450
Jx (cm ⁴)	25,294
Jy (cm ⁴)	11,292

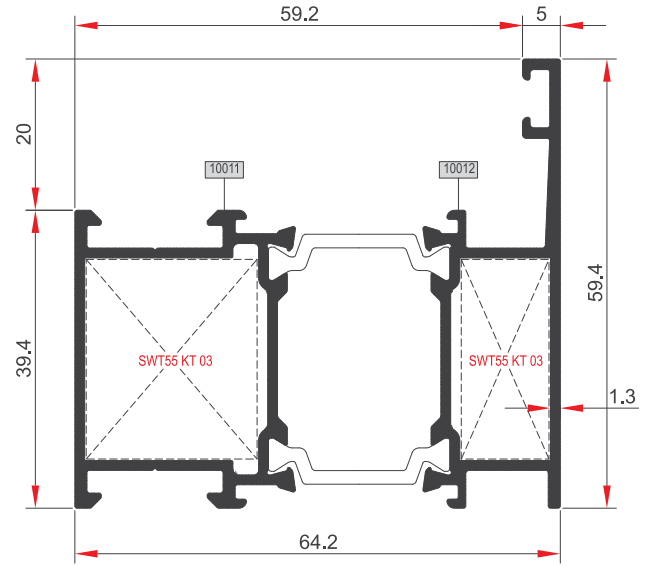

SWT64 KS 06

AĞIRLIK (kg/m) / WEIGHT kg/m	1.292
Jx (cm ⁴)	22,180
Jy (cm ⁴)	10,258

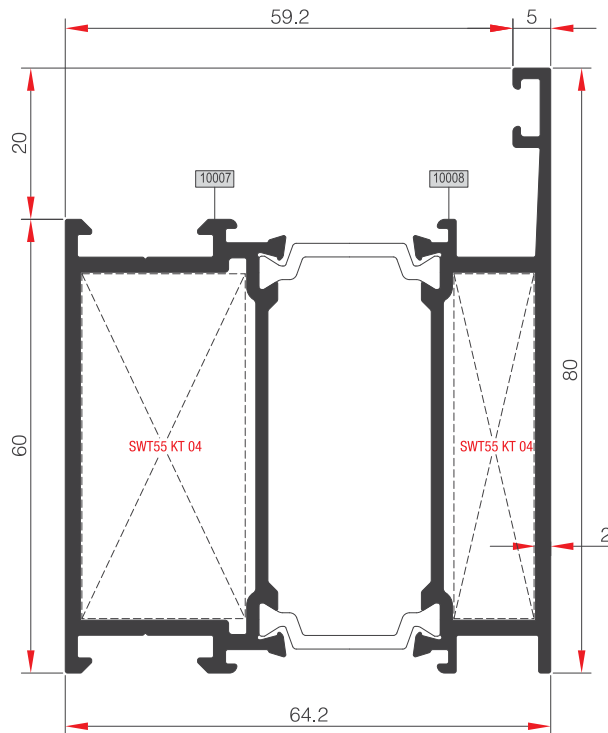

SWT64 KS 04

AĞIRLIK (kg/m) / WEIGHT kg/m	1.972
Jx (cm ⁴)	37.359
Jy (cm ⁴)	31.709

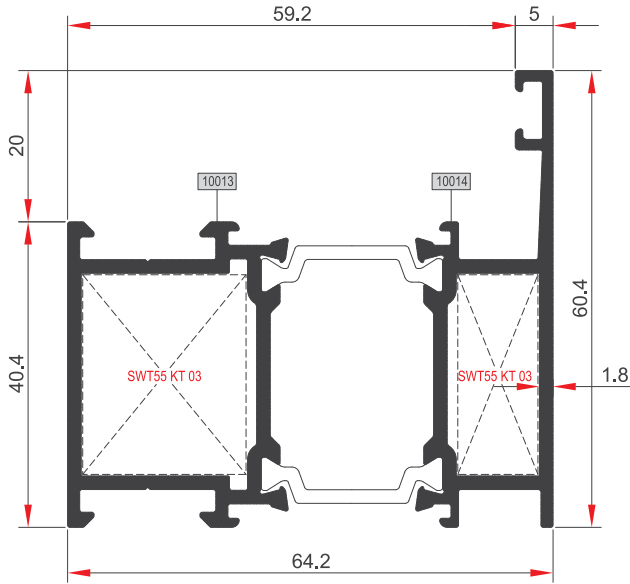

SWT64 KS 07

AĞIRLIK (kg/m) / WEIGHT kg/m	1.557
Jx (cm ⁴)	27,356
Jy (cm ⁴)	11,995

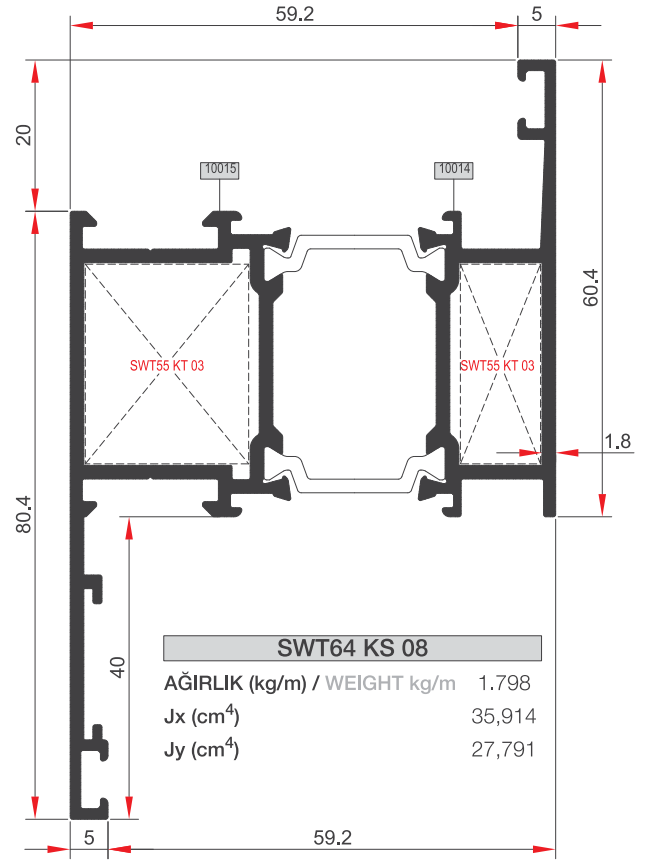

SWT64 KS 08

AĞIRLIK (kg/m) / WEIGHT kg/m	1.798
Jx (cm ⁴)	35,914
Jy (cm ⁴)	27,791

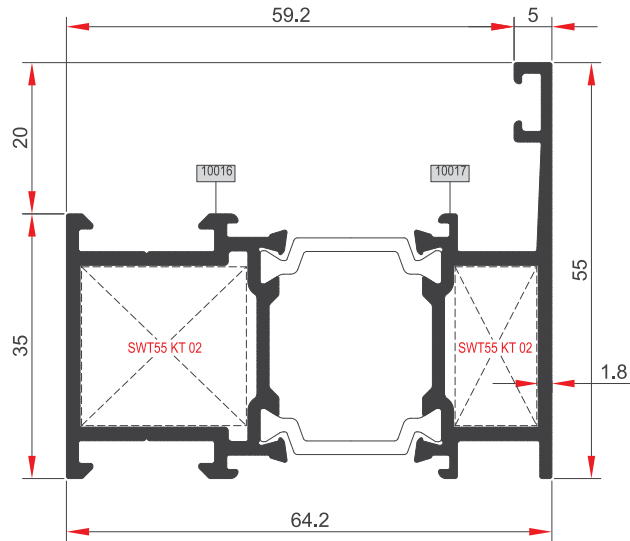

SWT64 KS 09

AĞIRLIK (kg/m) / WEIGHT kg/m	1.426
Jx (cm ⁴)	25,002
Jy (cm ⁴)	8,574

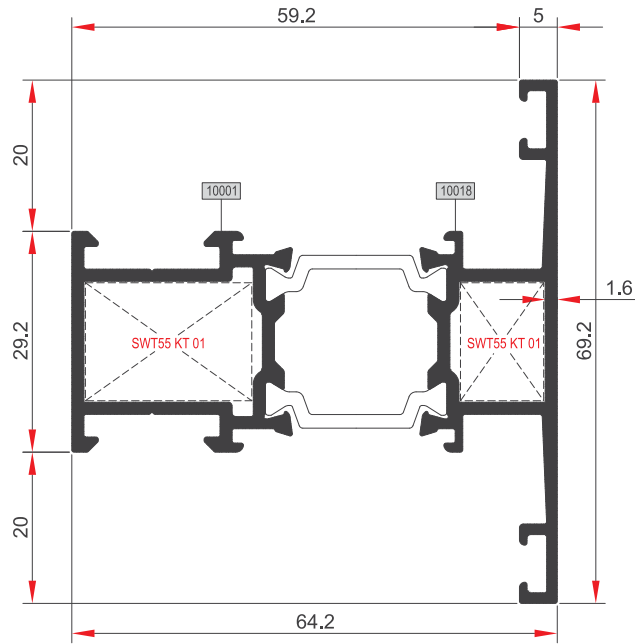

SWT64 KY 01

AĞIRLIK (kg/m) / WEIGHT kg/m	1,383
Jx (cm ⁴)	24,389
Jy (cm ⁴)	8,928

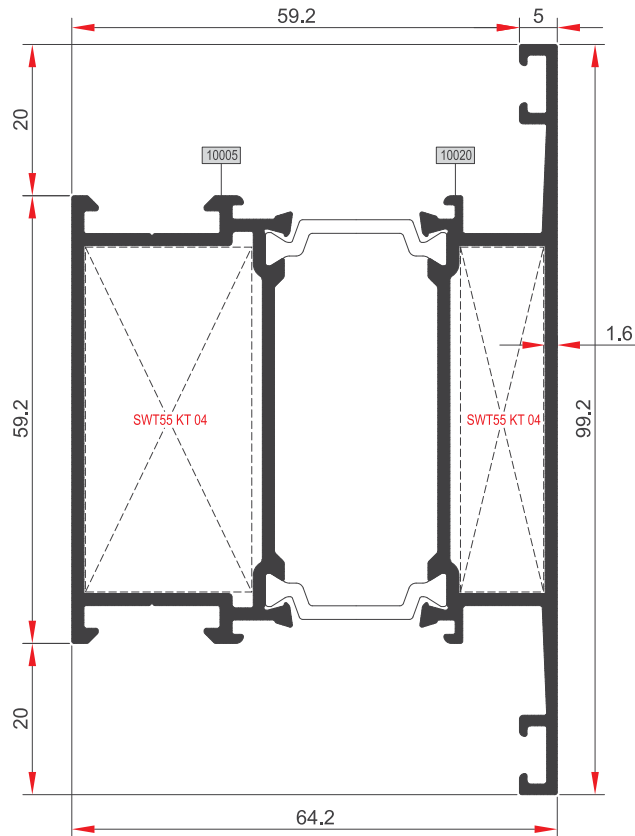

SWT64 KY 03

AĞIRLIK (kg/m) / WEIGHT kg/m	1,901
Jx (cm ⁴)	35,360
Jy (cm ⁴)	36,344

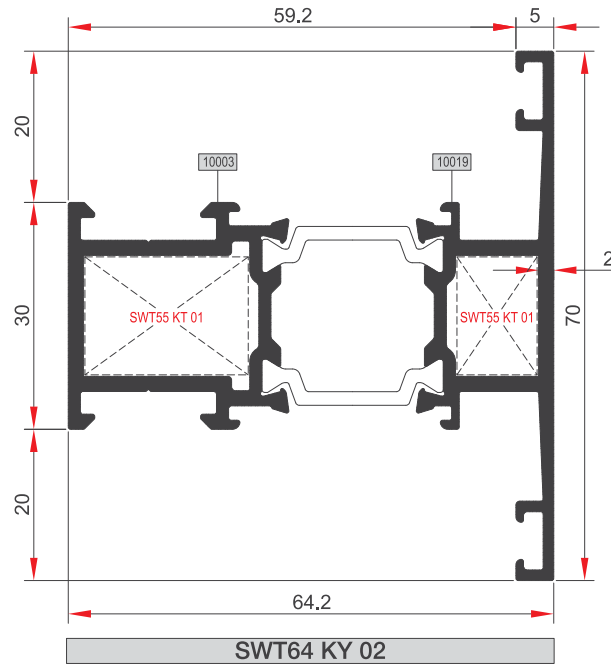

AĞIRLIK (kg/m) / WEIGHT kg/m	1.508
Jx (cm ⁴)	27,454
Jy (cm ⁴)	9,584

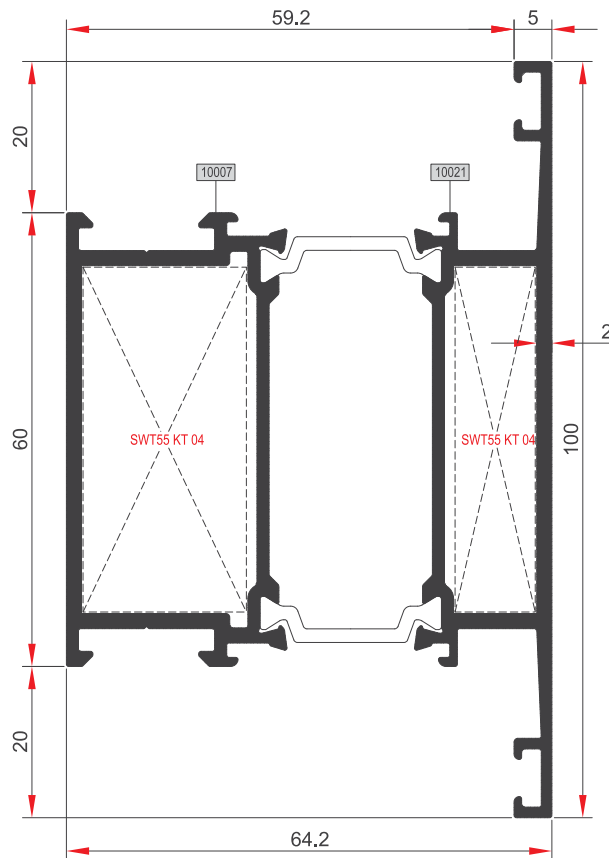

AĞIRLIK (kg/m) / WEIGHT kg/m	2,091
Jx (cm ⁴)	40,619
Jy (cm ⁴)	39,647

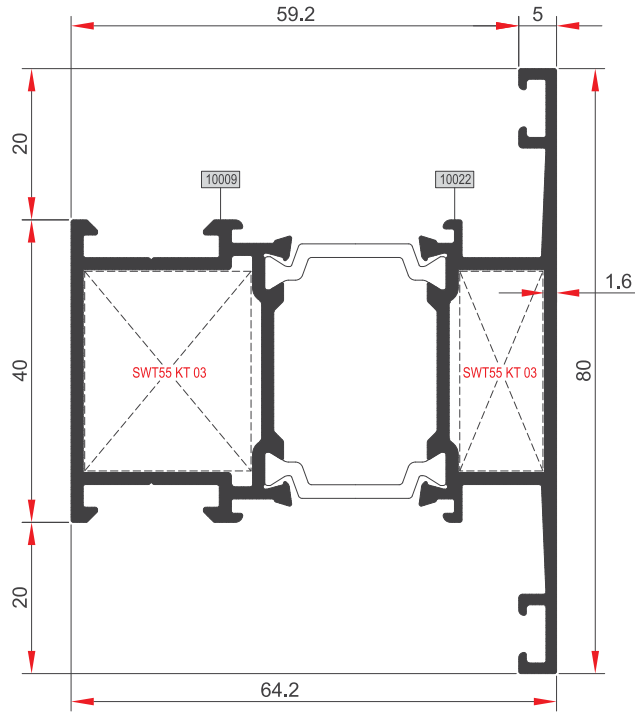

SWT64 KY 05

AĞIRLIK (kg/m) / WEIGHT kg/m	1,569
Jx (cm ⁴)	28,349
Jy (cm ⁴)	15,990

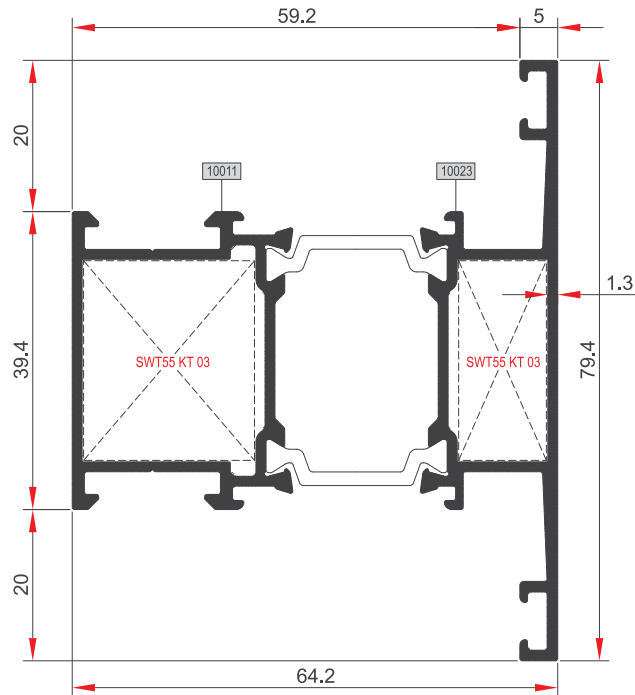

SWT64 KY 06

AĞIRLIK (kg/m) / WEIGHT kg/m	1,411
Jx (cm ⁴)	25,104
Jy (cm ⁴)	14,921

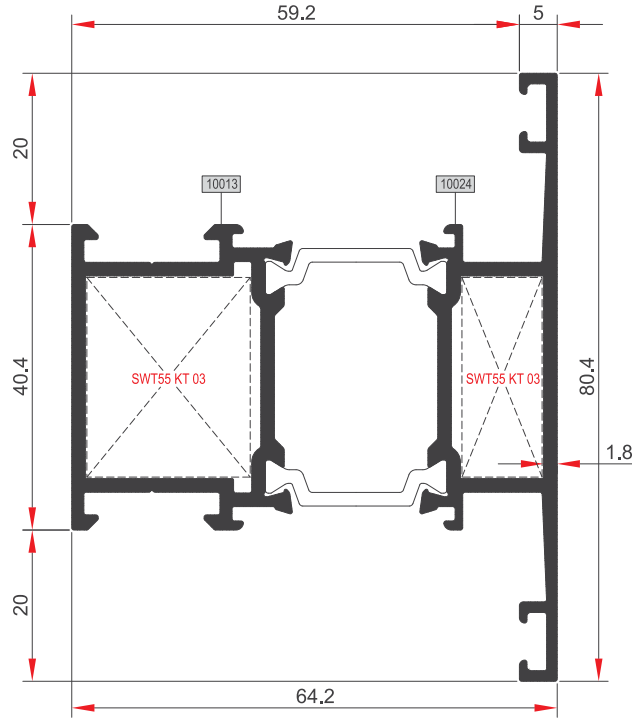

SWT64 KY 07

AĞIRLIK (kg/m) / WEIGHT kg/m	1,676
Jx (cm ⁴)	30,485
Jy (cm ⁴)	16,723

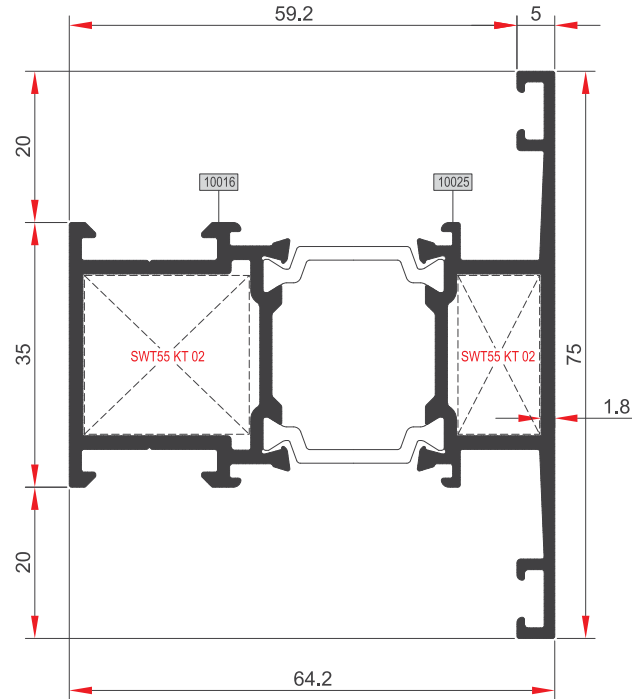

SWT64 KY 08

AĞIRLIK (kg/m) / WEIGHT kg/m	1,545
Jx (cm ⁴)	28,113
Jy (cm ⁴)	12,571

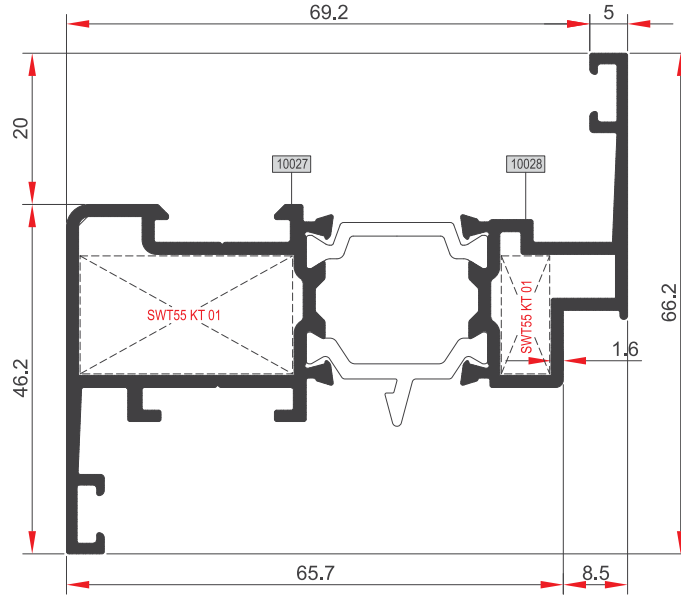

SWT64 KN 01

AĞIRLIK (kg/m) / WEIGHT kg/m	1,455
Jx (cm ⁴)	33,493
Jy (cm ⁴)	8,215

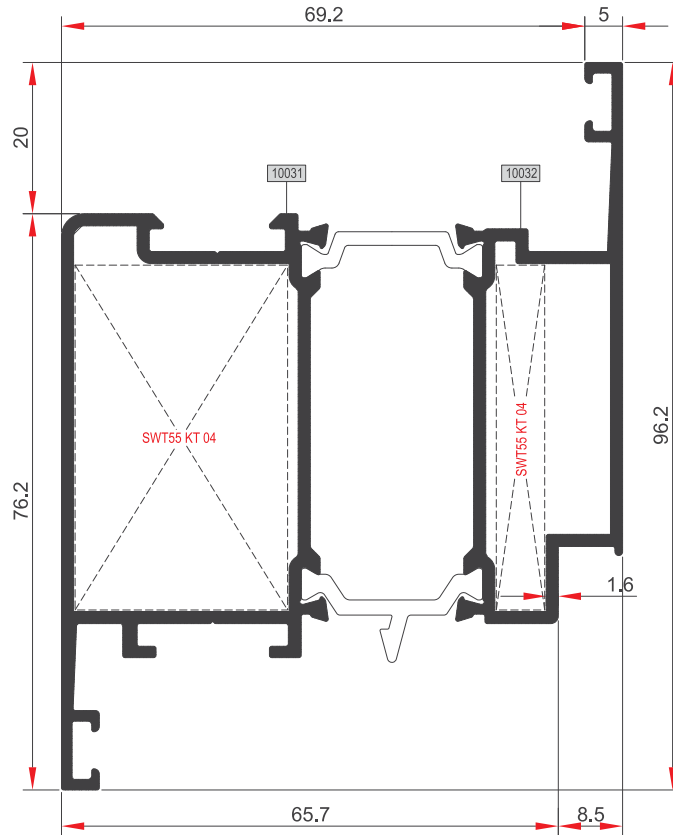

SWT64 KN 03

AĞIRLIK (kg/m) / WEIGHT kg/m	1,973
Jx (cm ⁴)	47,931
Jy (cm ⁴)	35,569

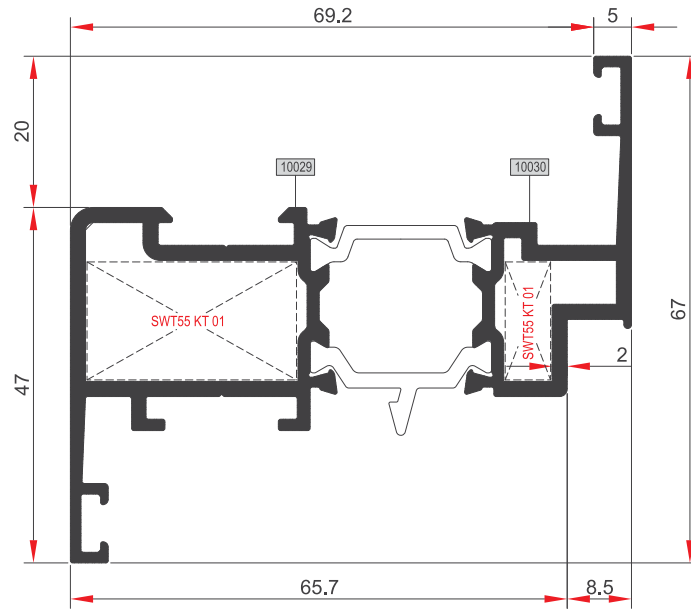

SWT64 KN 02

AĞIRLIK (kg/m) / WEIGHT kg/m	1,610
Jx (cm ⁴)	37,763
Jy (cm ⁴)	8,944

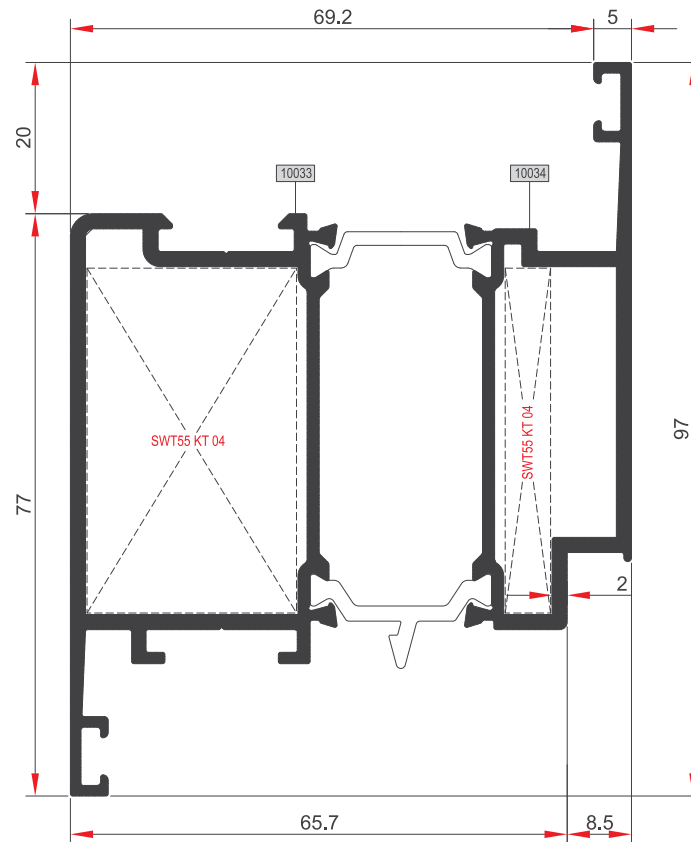

SWT64 KN 04

AĞIRLIK (kg/m) / WEIGHT kg/m	2,194
Jx (cm ⁴)	55,244
Jy (cm ⁴)	39,446

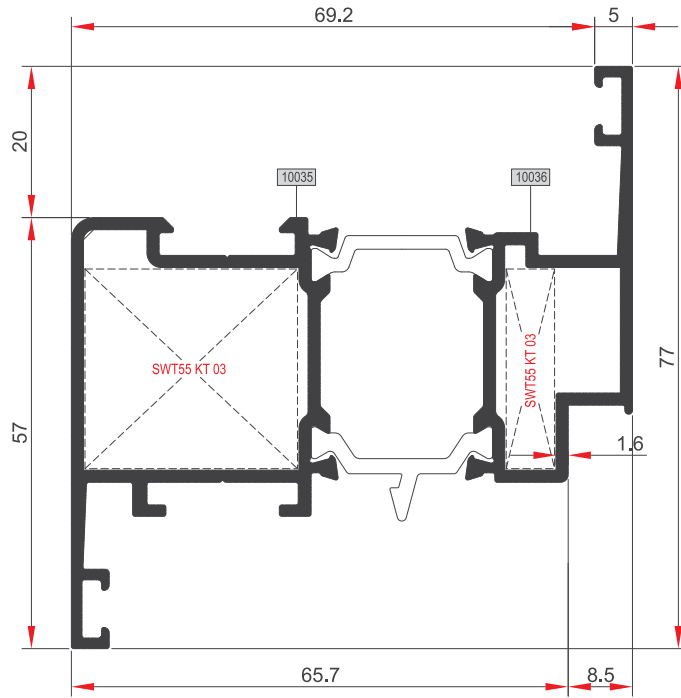

SWT64 KN 05

AĞIRLIK (kg/m) / WEIGHT kg/m	1,642
Jx (cm ⁴)	38,714
Jy (cm ⁴)	15,156

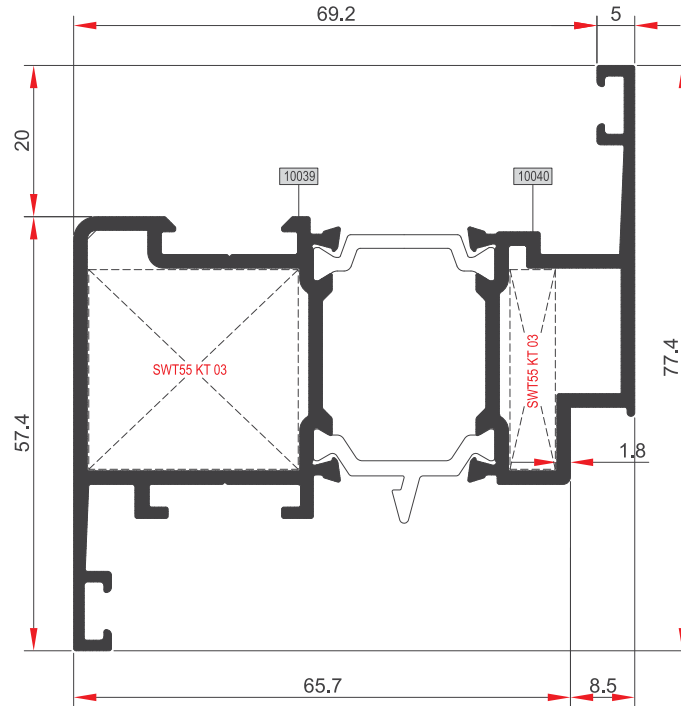

SWT64 KN 07

AĞIRLIK (kg/m) / WEIGHT kg/m	1,762
Jx (cm ⁴)	41,678
Jy (cm ⁴)	15,983

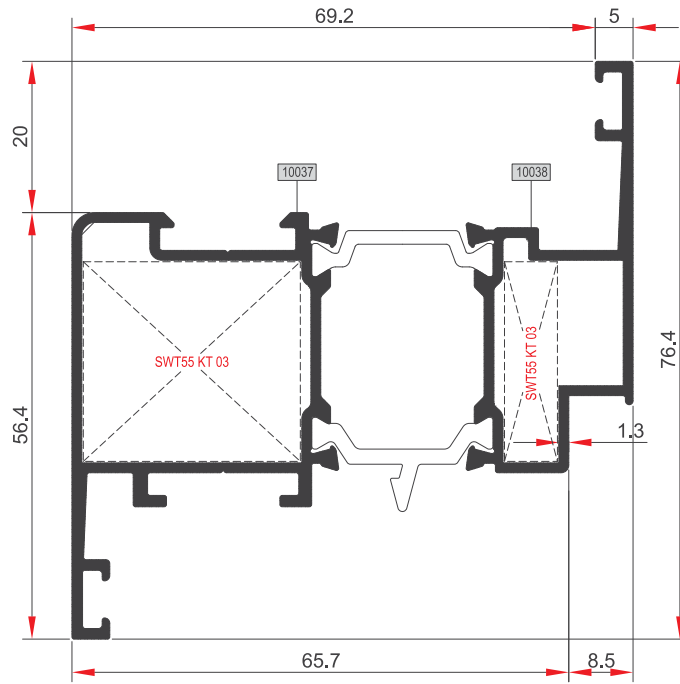

SWT64 KN 06

AĞIRLIK (kg/m) / WEIGHT kg/m	1,461
Jx (cm ⁴)	34,258
Jy (cm ⁴)	13,944

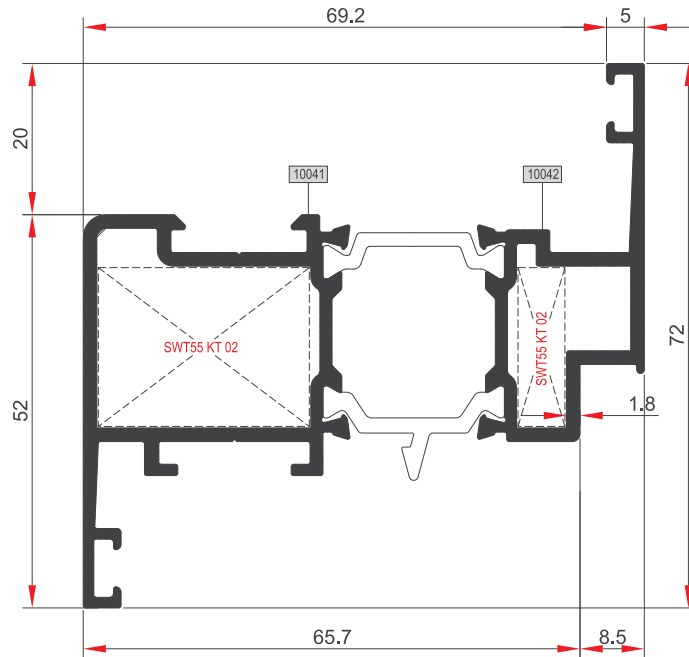

SWT64 KN 08

AĞIRLIK (kg/m) / WEIGHT kg/m	1,632
Jx (cm ⁴)	38,526
Jy (cm ⁴)	11,846

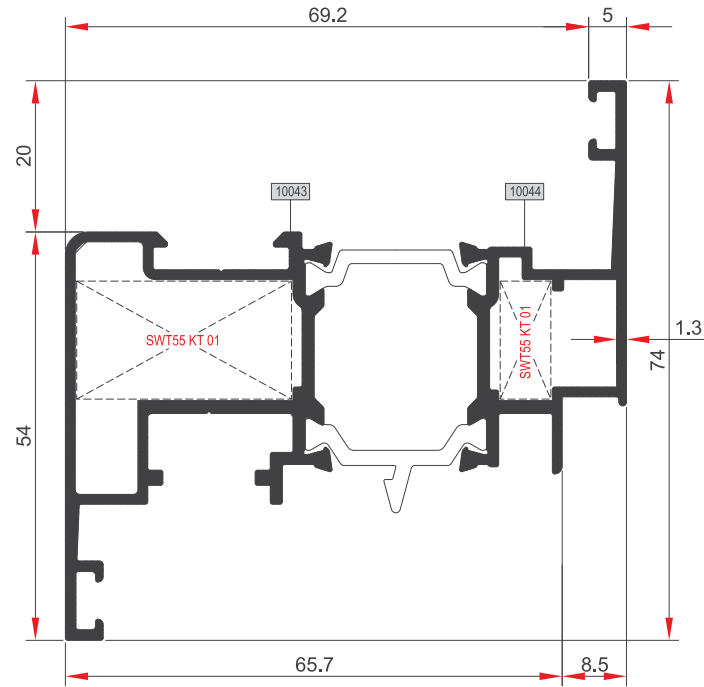

SWT64 KN 09

AĞIRLIK (kg/m) / WEIGHT kg/m	1,545
Jx (cm ⁴)	34,606
Jy (cm ⁴)	11,932

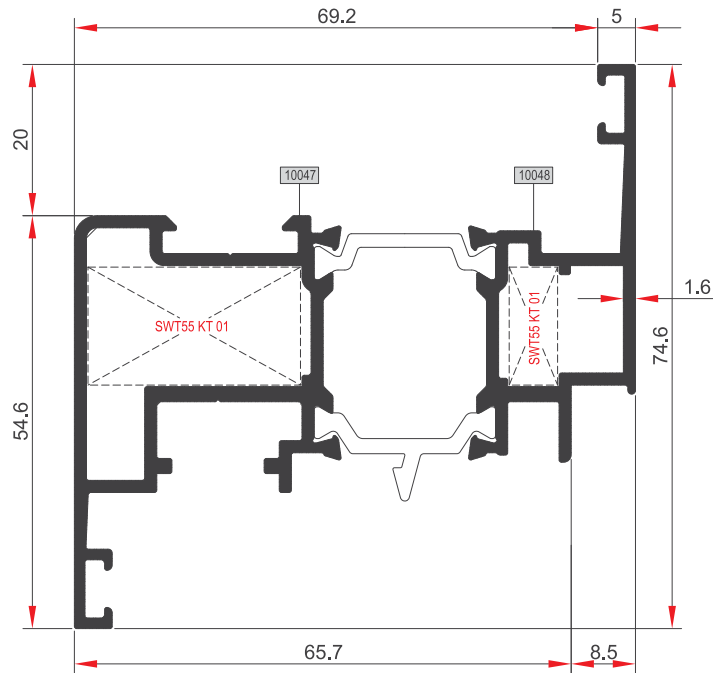

SWT64 KN 11

AĞIRLIK (kg/m) / WEIGHT kg/m	1,686
Jx (cm ⁴)	38,820
Jy (cm ⁴)	12,848

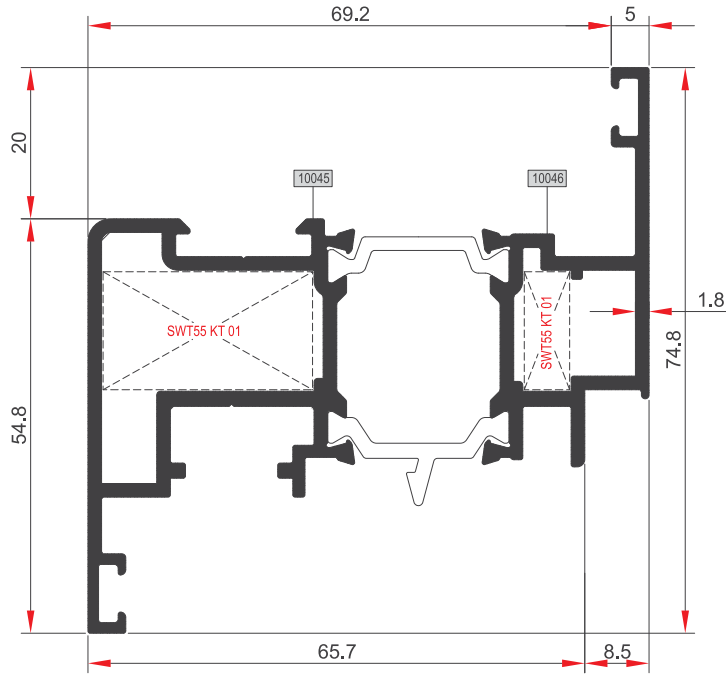

SWT64 KN 10

AĞIRLIK (kg/m) / WEIGHT kg/m	1,796
Jx (cm ⁴)	41,880
Jy (cm ⁴)	13,524

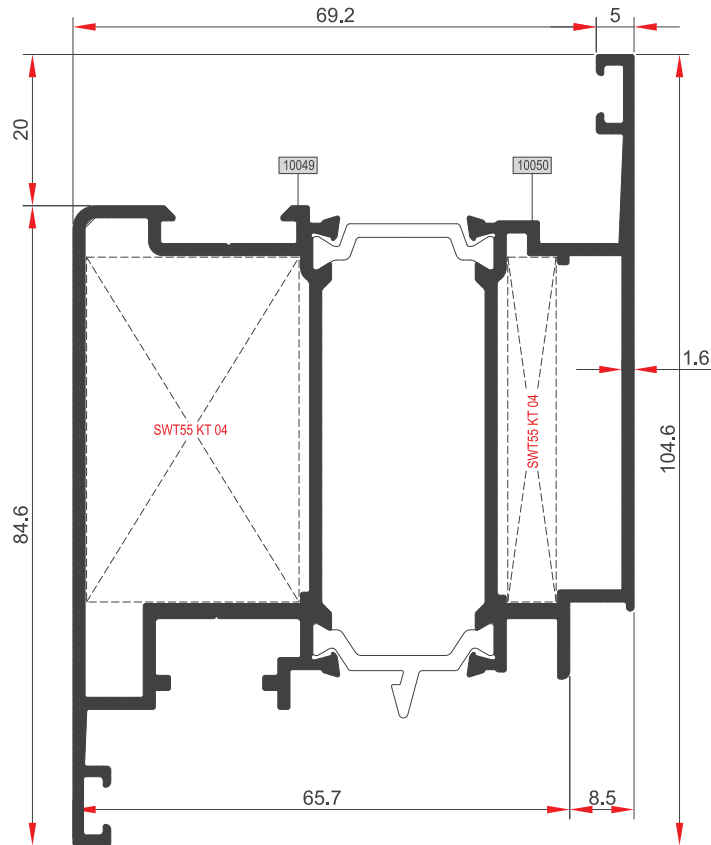

SWT64 KN 12

AĞIRLIK (kg/m) / WEIGHT kg/m	2,205
Jx (cm ⁴)	53,281
Jy (cm ⁴)	48,130

SWT64

KANAT VE ETEK PROFİLLERİ
SASH AND KICKPLATE PROFILES

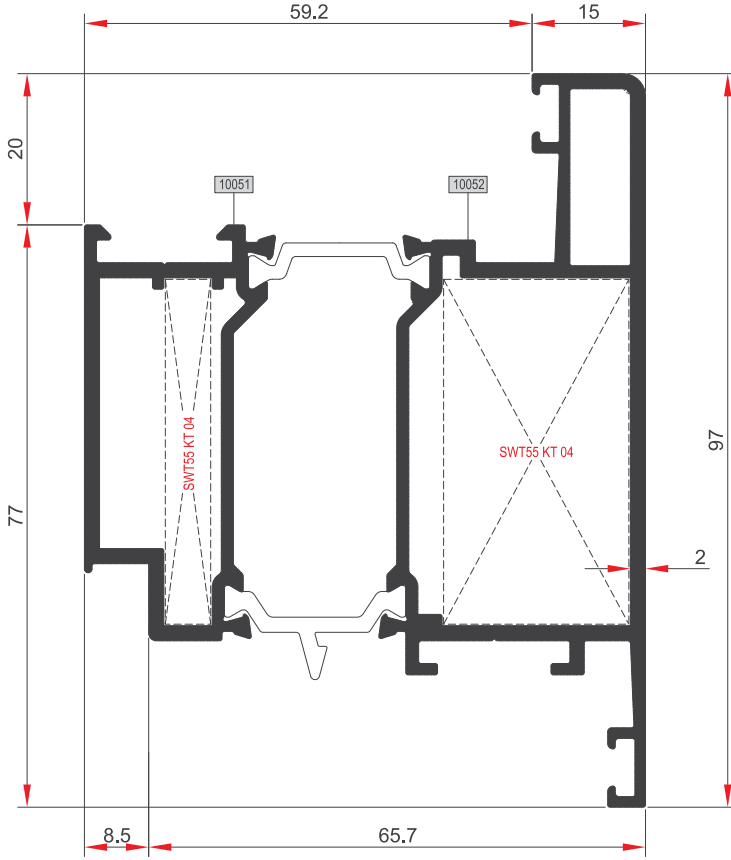

SWT64 KN 13

AĞIRLIK (kg/m) / WEIGHT kg/m	2,368
Jx (cm ⁴)	56,942
Jy (cm ⁴)	48,221

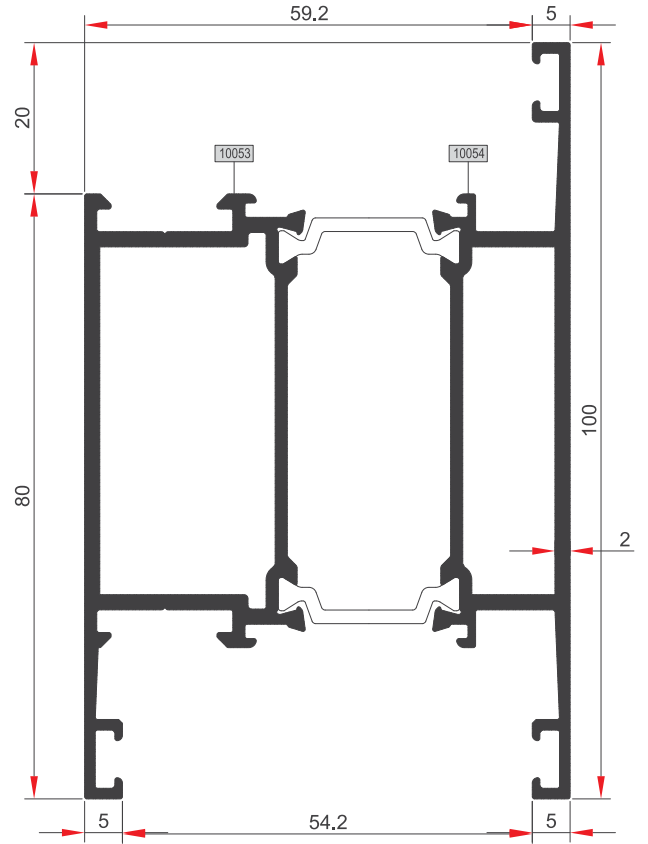

SWT64 KE 01

AĞIRLIK (kg/m) / WEIGHT kg/m	2,206
Jx (cm ⁴)	45,478
Jy (cm ⁴)	46,573

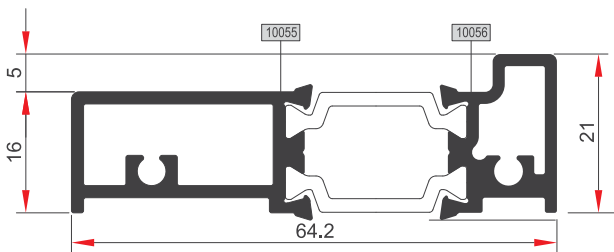

SWT64 KE 02

AĞIRLIK (kg/m) / WEIGHT kg/m	0,993
Jx (cm ⁴)	14,993
Jy (cm ⁴)	1,082

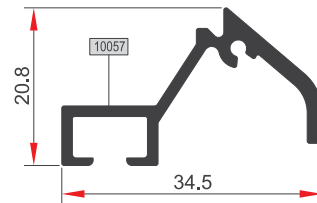

SWT64 KE 03

AĞIRLIK (kg/m) / WEIGHT kg/m	0,315
Jx (cm ⁴)	1,306
Jy (cm ⁴)	0,346

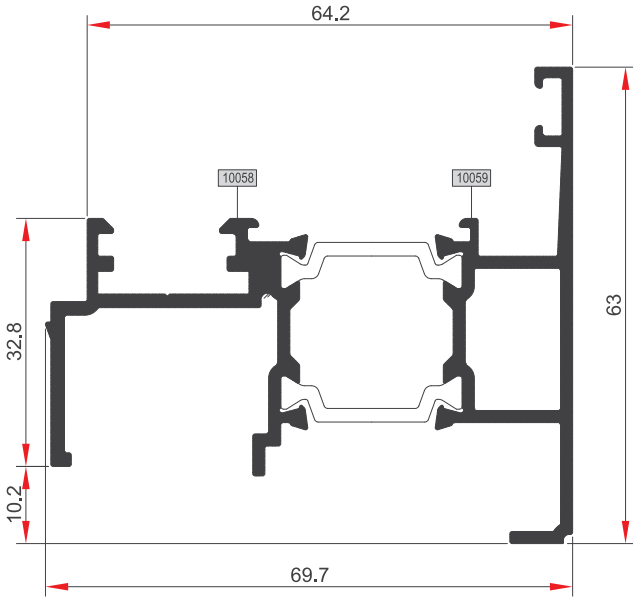

SWT64 AD 01

AĞIRLIK (kg/m) / WEIGHT kg/m	1,377
Jx (cm ⁴)	26,075
Jy (cm ⁴)	7,773

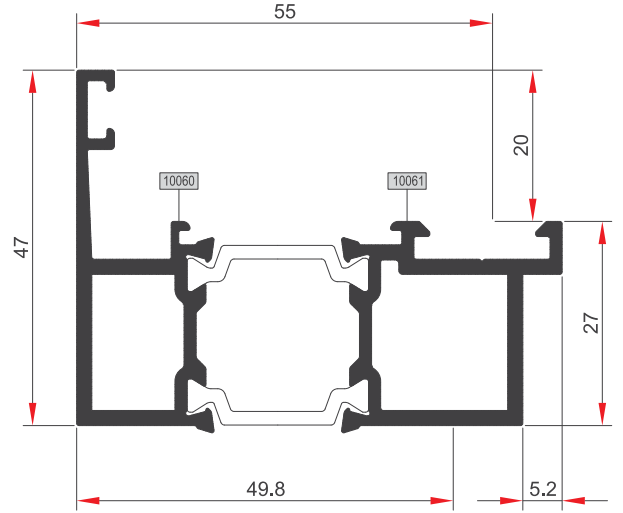

SWT64 AD 02

AĞIRLIK (kg/m) / WEIGHT kg/m	1,281
Jx (cm ⁴)	20,412
Jy (cm ⁴)	5,543

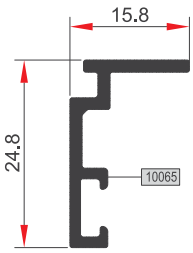

SWT55 AD 05

AĞIRLIK (kg/m) / WEIGHT kg/m	0,205
Jx (cm ⁴)	0,122
Jy (cm ⁴)	0,523

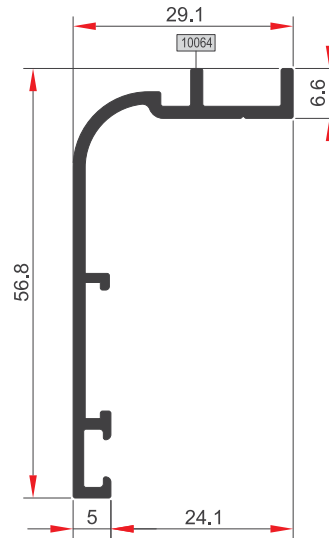

SWT55 AD 04

AĞIRLIK (kg/m) / WEIGHT kg/m	0,429
Jx (cm ⁴)	1,330
Jy (cm ⁴)	5,343

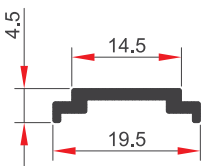

SWT55 T 01

AĞIRLIK (kg/m) / WEIGHT kg/m	0,105
Jx (cm ⁴)	0,144
Jy (cm ⁴)	0,005

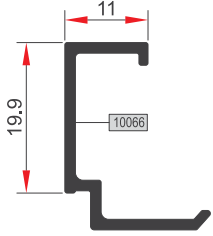

SWT55 C 01	
AĞIRLIK (kg/m) / WEIGHT kg/m	0,205
Jx (cm ⁴)	0,206
Jy (cm ⁴)	0,666

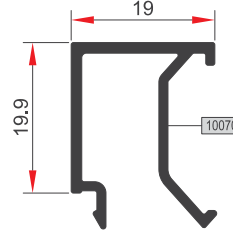

SWT55 C 05	
AĞIRLIK (kg/m) / WEIGHT kg/m	0,261
Jx (cm ⁴)	0,383
Jy (cm ⁴)	0,638

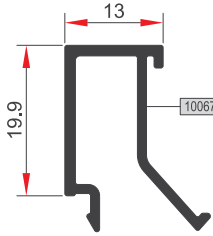

SWT55 C 02	
AĞIRLIK (kg/m) / WEIGHT kg/m	0,237
Jx (cm ⁴)	0,261
Jy (cm ⁴)	0,558

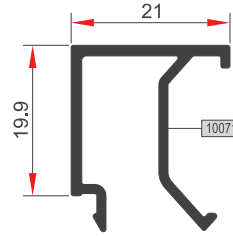

SWT55 C 06	
AĞIRLIK (kg/m) / WEIGHT kg/m	0,269
Jx (cm ⁴)	0,429
Jy (cm ⁴)	0,660

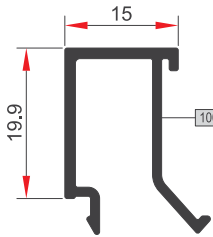

SWT55 C 03	
AĞIRLIK (kg/m) / WEIGHT kg/m	0,242
Jx (cm ⁴)	0,309
Jy (cm ⁴)	0,582

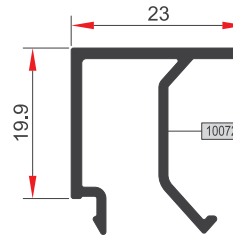

SWT55 C 07	
AĞIRLIK (kg/m) / WEIGHT kg/m	0,277
Jx (cm ⁴)	0,488
Jy (cm ⁴)	0,681

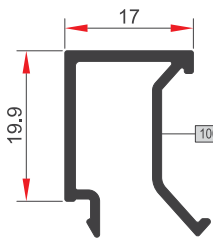

SWT55 C 04	
AĞIRLIK (kg/m) / WEIGHT kg/m	0,254
Jx (cm ⁴)	0,348
Jy (cm ⁴)	0,615

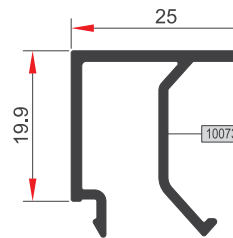

SWT55 C 08	
AĞIRLIK (kg/m) / WEIGHT kg/m	0,284
Jx (cm ⁴)	0,561
Jy (cm ⁴)	0,701

SWT64

CAM ÇITA PROFİLLERİ
GLAZING BEAD PROFILES

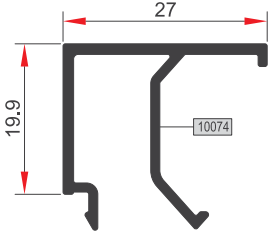

SWT55 C 09

AĞIRLIK (kg/m) / WEIGHT kg/m	0,292
Jx (cm ⁴)	0,648
Jy (cm ⁴)	0,719

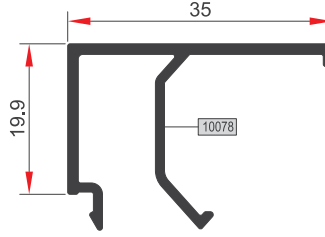

SWT55 C 13

AĞIRLIK (kg/m) / WEIGHT kg/m	0,322
Jx (cm ⁴)	1,064
Jy (cm ⁴)	0,786

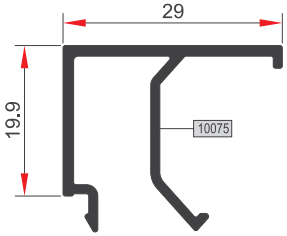

SWT55 C 10

AĞIRLIK (kg/m) / WEIGHT kg/m	0,299
Jx (cm ⁴)	0,751
Jy (cm ⁴)	0,737

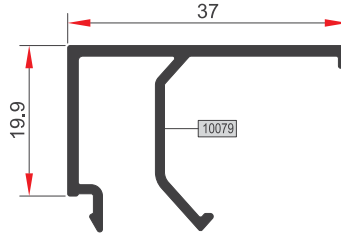

SWT55 C 14

AĞIRLIK (kg/m) / WEIGHT kg/m	0,329
Jx (cm ⁴)	1,340
Jy (cm ⁴)	0,801

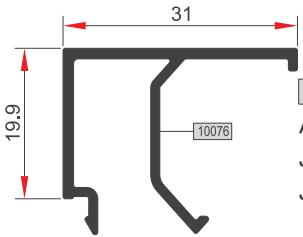

SWT55 C 11

AĞIRLIK (kg/m) / WEIGHT kg/m	0,307
Jx (cm ⁴)	0,871
Jy (cm ⁴)	0,754

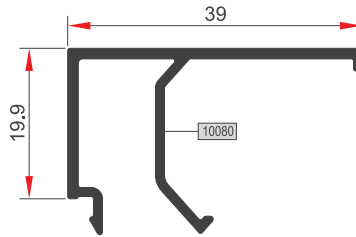

SWT55 C 14

AĞIRLIK (kg/m) / WEIGHT kg/m	0,304
Jx (cm ⁴)	1,536
Jy (cm ⁴)	0,815

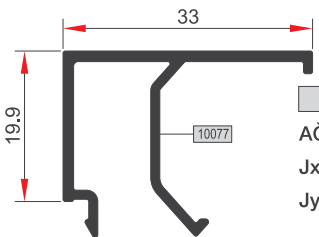

SWT55 C 12

AĞIRLIK (kg/m) / WEIGHT kg/m	0,314
Jx (cm ⁴)	1,008
Jy (cm ⁴)	0,770

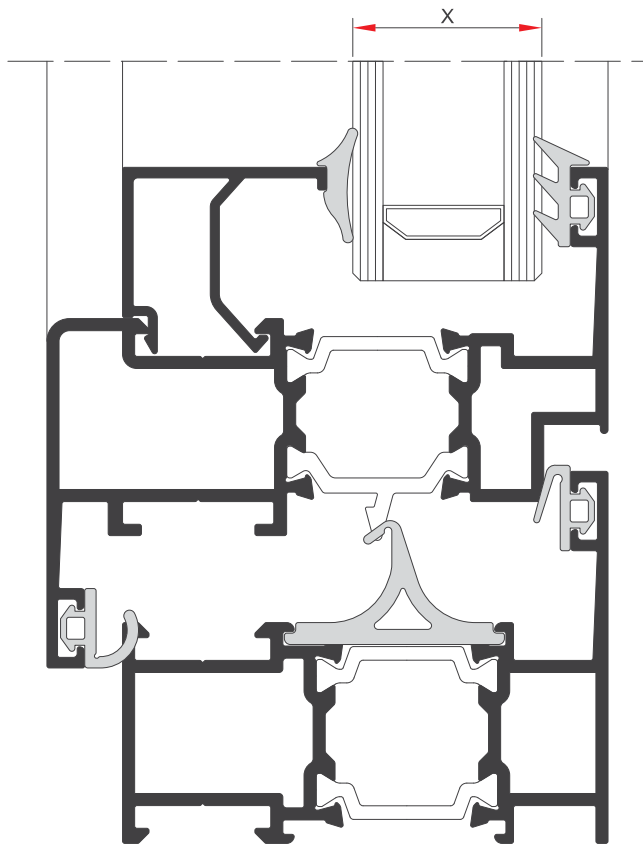

CAM TABLOSU - Glazing Table

		
	FITIL004	FITIL005
SWT55 C 01	41 mm	40 mm
SWT55 C 02	39 mm	38 mm
SWT55 C 03	37 mm	36 mm
SWT55 C 04	35 mm	34 mm
SWT55 C 05	33 mm	32 mm
SWT55 C 06	31 mm	30 mm
SWT55 C 07	29 mm	28 mm
SWT55 C 08	27 mm	26 mm
SWT55 C 09	25 mm	24 mm
SWT55 C 10	23 mm	22 mm
SWT55 C 11	21 mm	20 mm
SWT55 C 12	19 mm	18 mm
SWT55 C 13	17 mm	16 mm
SWT55 C 14	15 mm	14 mm
SWT55 C 15	13 mm	12 mm

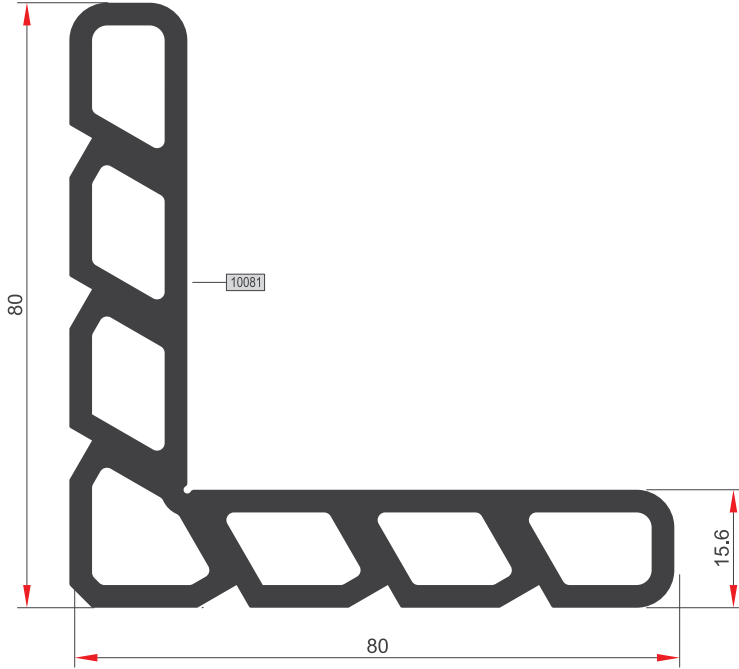

SWT55 KT 01

AĞIRLIK (kg/m) / WEIGHT kg/m	3,226
Jx (cm ⁴)	66,802
Jy (cm ⁴)	66,802

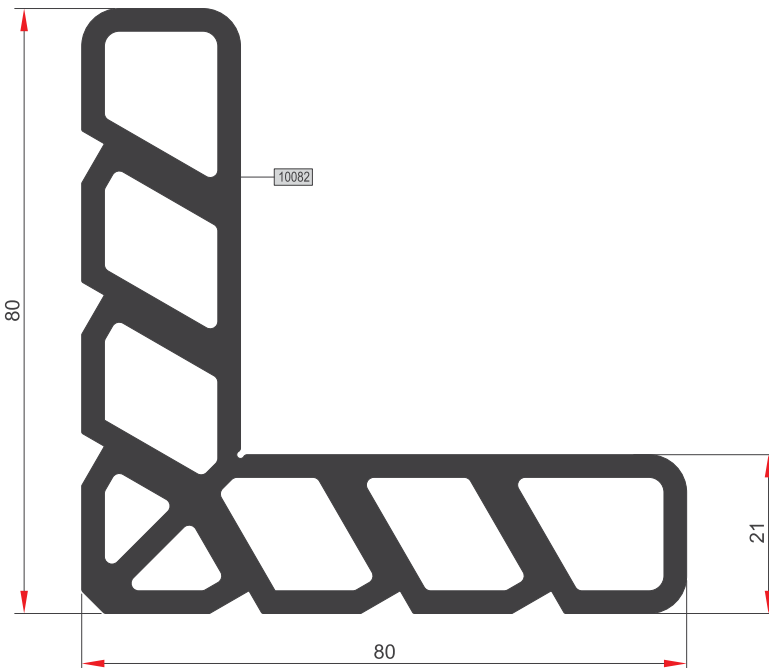

SWT55 KT 02

AĞIRLIK (kg/m) / WEIGHT kg/m	3,788
Jx (cm ⁴)	74,787
Jy (cm ⁴)	74,787

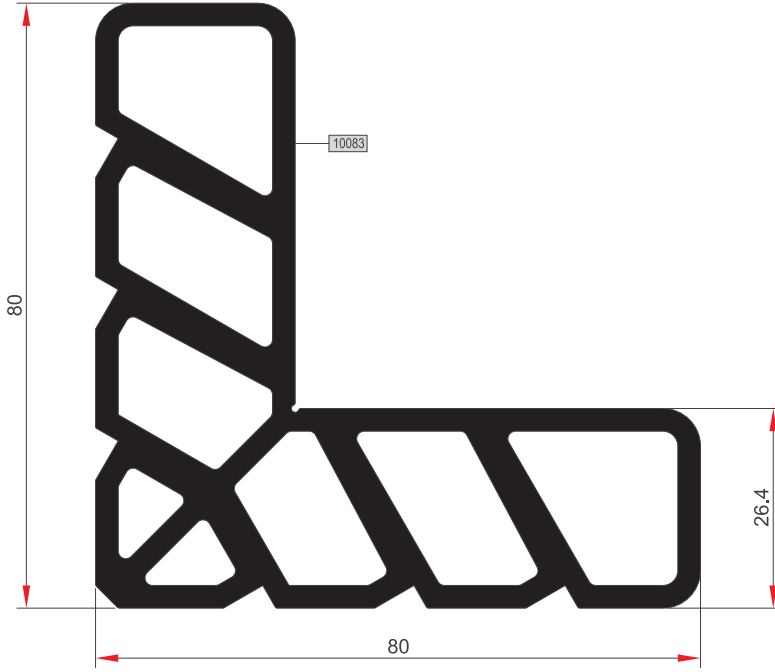

SWT55 KT 03

AĞIRLIK (kg/m) / WEIGHT kg/m	4,109
Jx (cm ⁴)	79,786
Jy (cm ⁴)	79,786

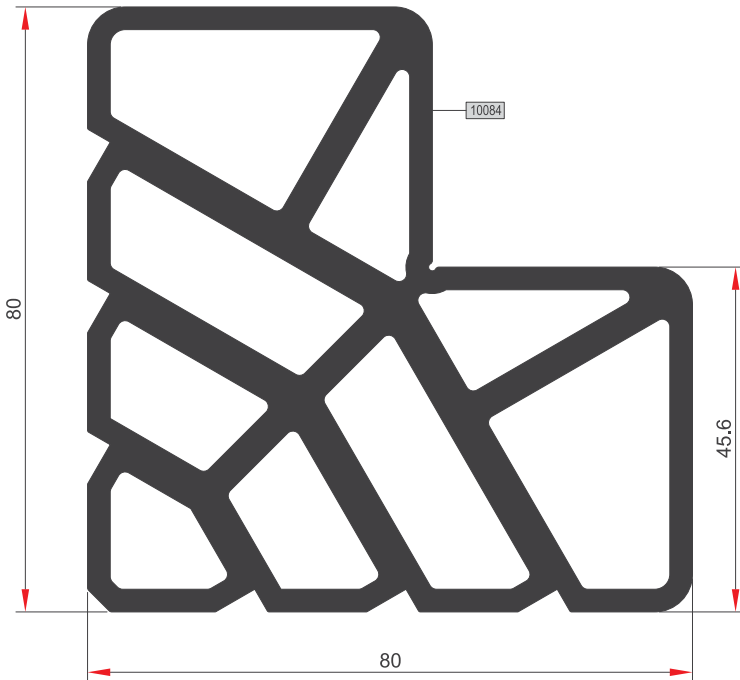

SWT55 KT 04

AĞIRLIK (kg/m) / WEIGHT kg/m	5,602
Jx (cm ⁴)	107,561
Jy (cm ⁴)	107,561

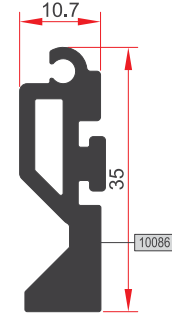
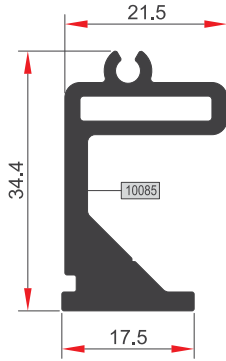

SWT55 KB 01

AĞIRLIK (kg/m) / WEIGHT kg/m	0,694
Jx (cm ⁴)	0,852
Jy (cm ⁴)	3,138

SWT55 KB 02

AĞIRLIK (kg/m) / WEIGHT kg/m	0,597
Jx (cm ⁴)	0,200
Jy (cm ⁴)	2,283

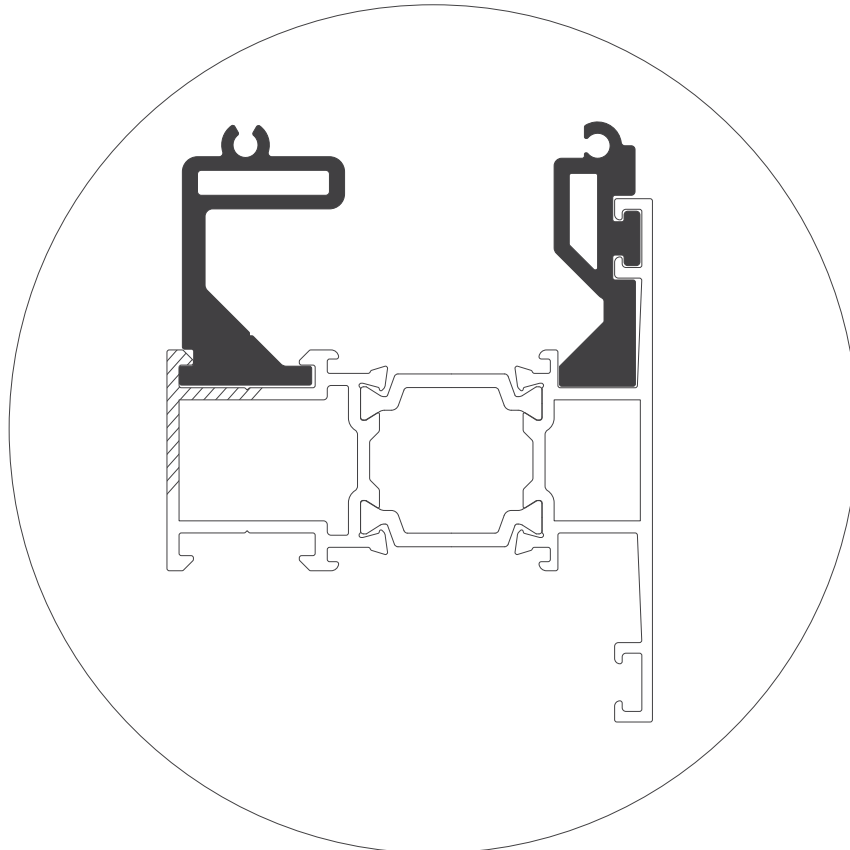

MiMARI KATALOG

ARCHITECTURAL CATALOGUE

Aluminyum Kapı Pencere ve Giydirme Cephe Sistemleri
Aluminium Window Doors and Facade Systems



ALUSYSTEMS
Profil Detayları

ALUSYSTEMS
Profile Details

SWT 64

DETAYLAR
DETAILS

ALUSYSTEMS

Aluminyum Kapı Pencere ve Giydirme Cephe Sistemleri
Aluminium Window Doors and Facade Systems



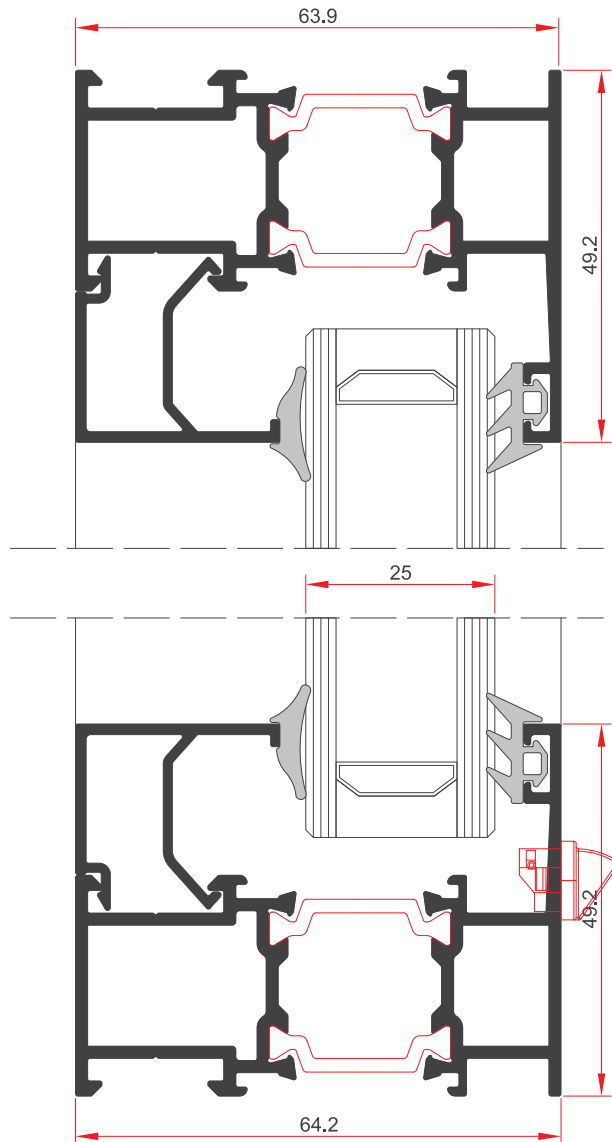
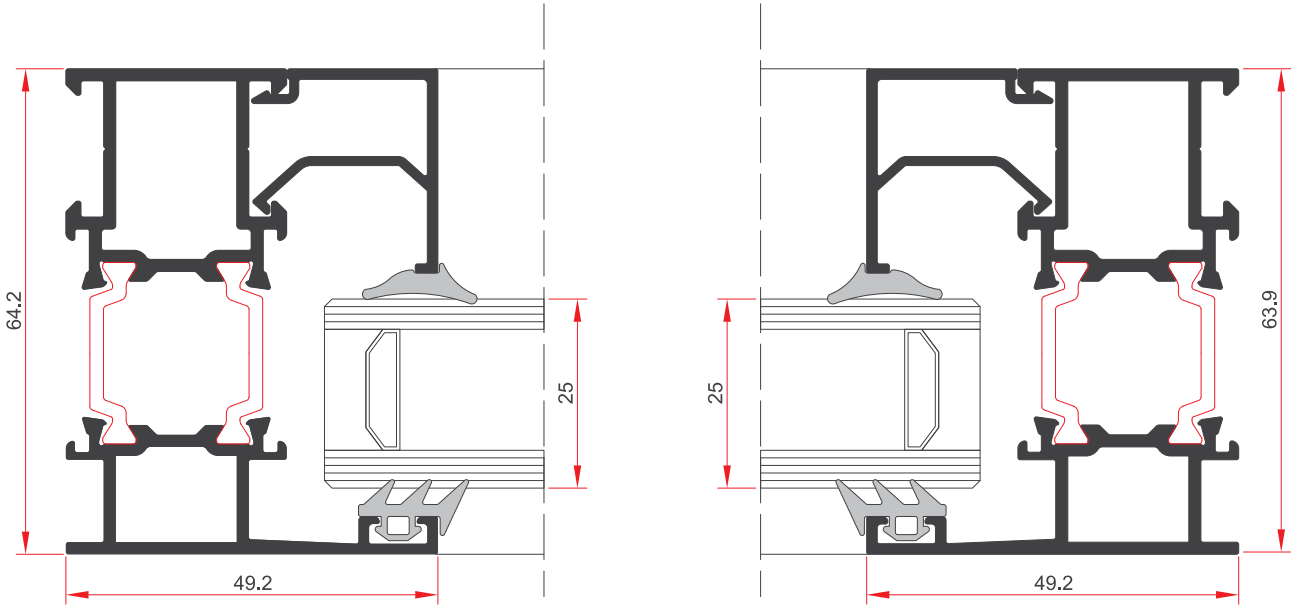

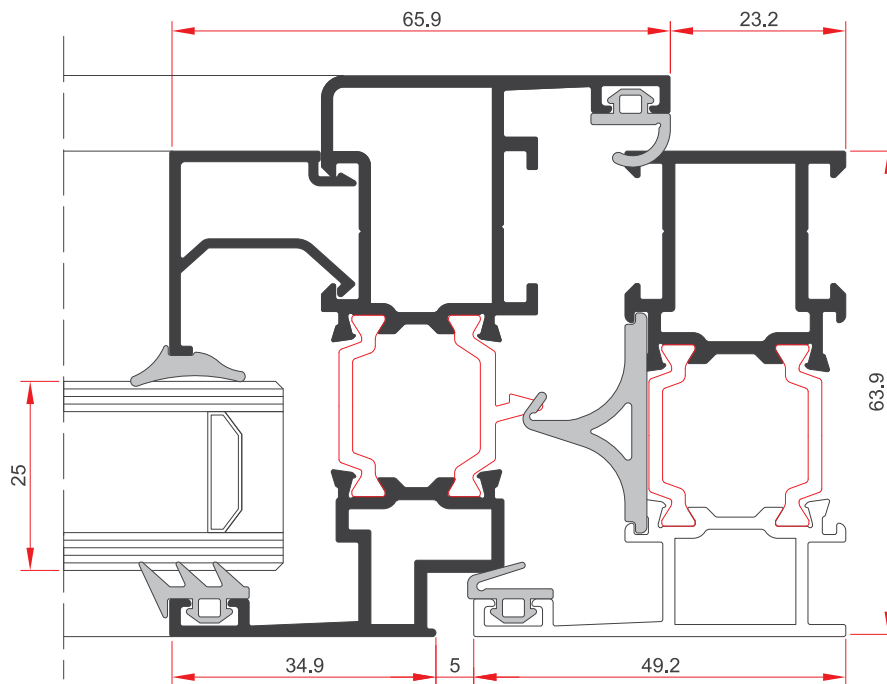
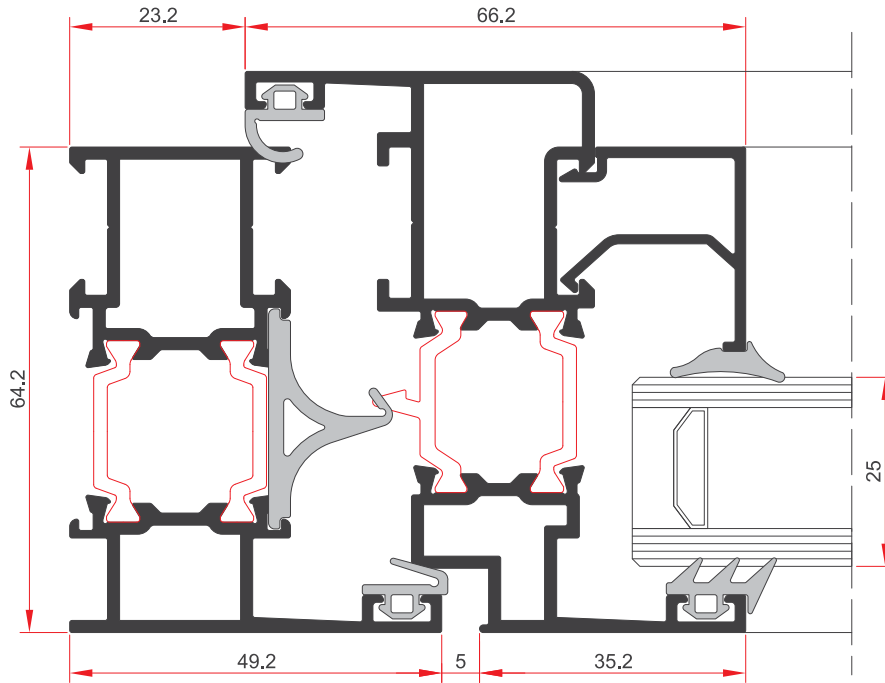

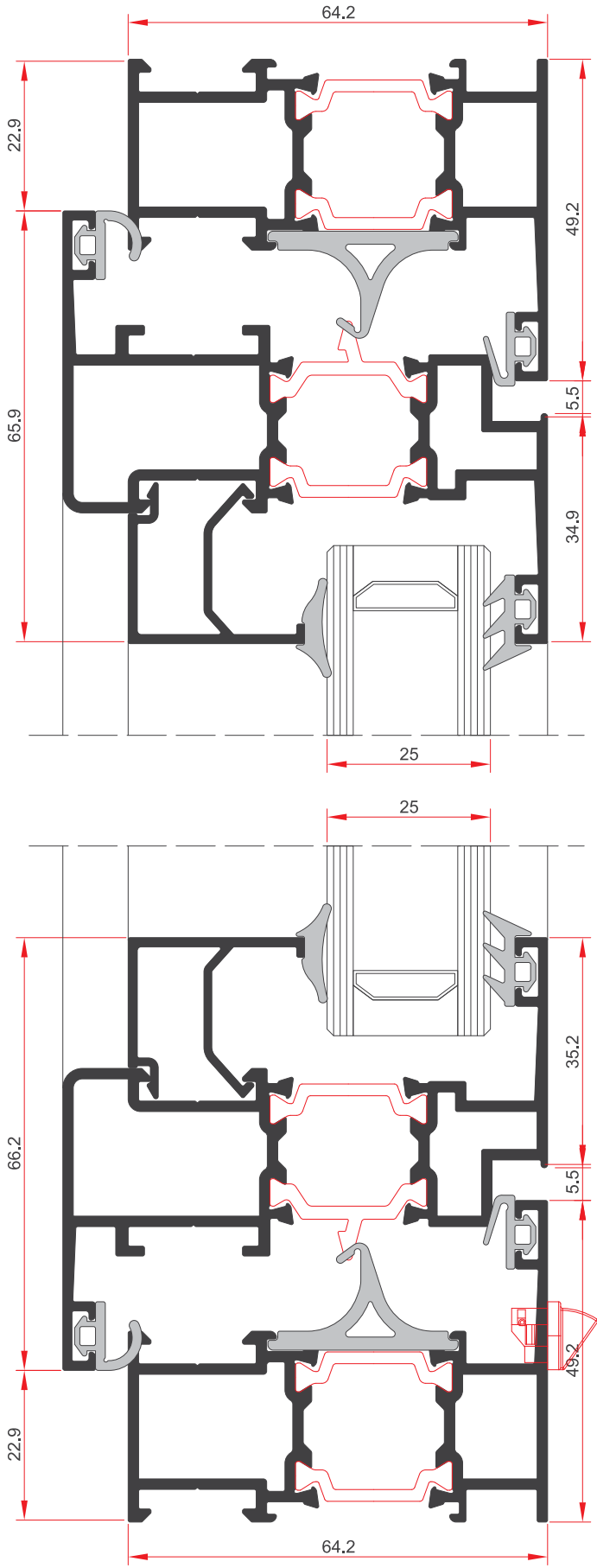

SWT64

DETAYLAR
DETAILS

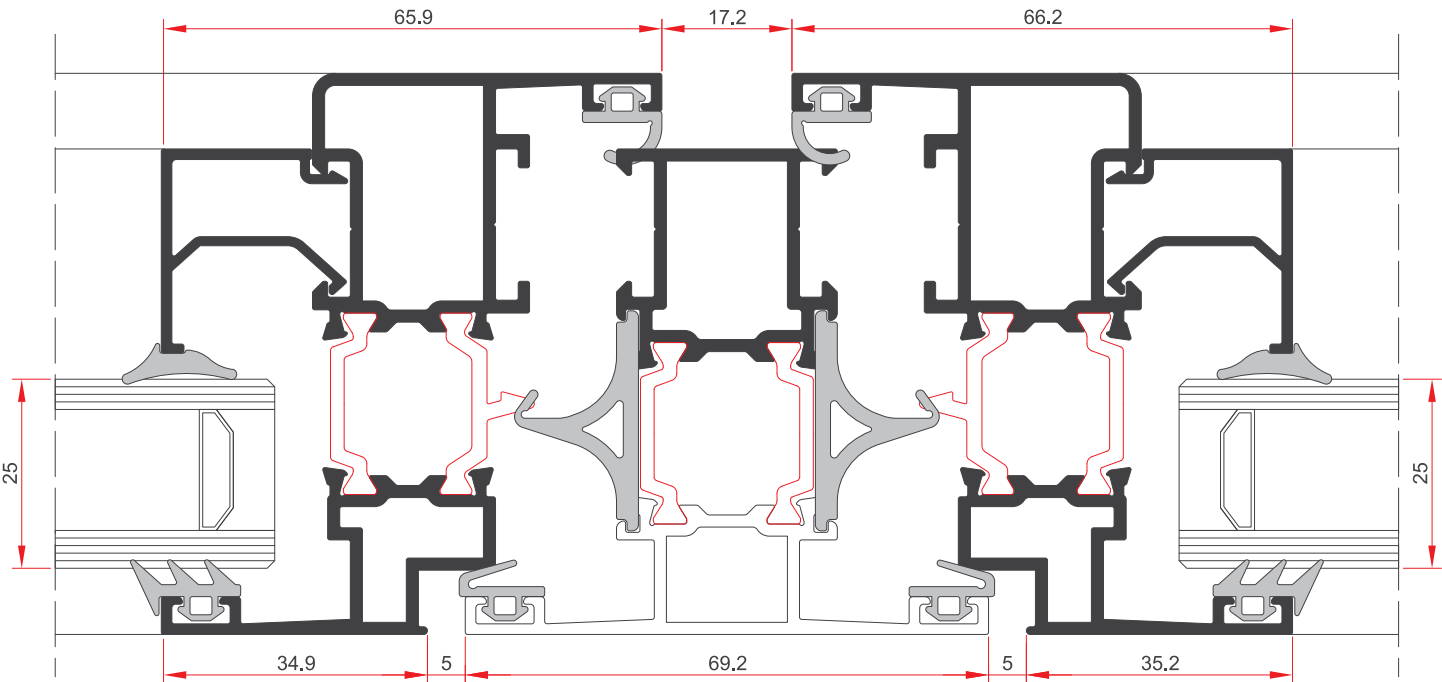
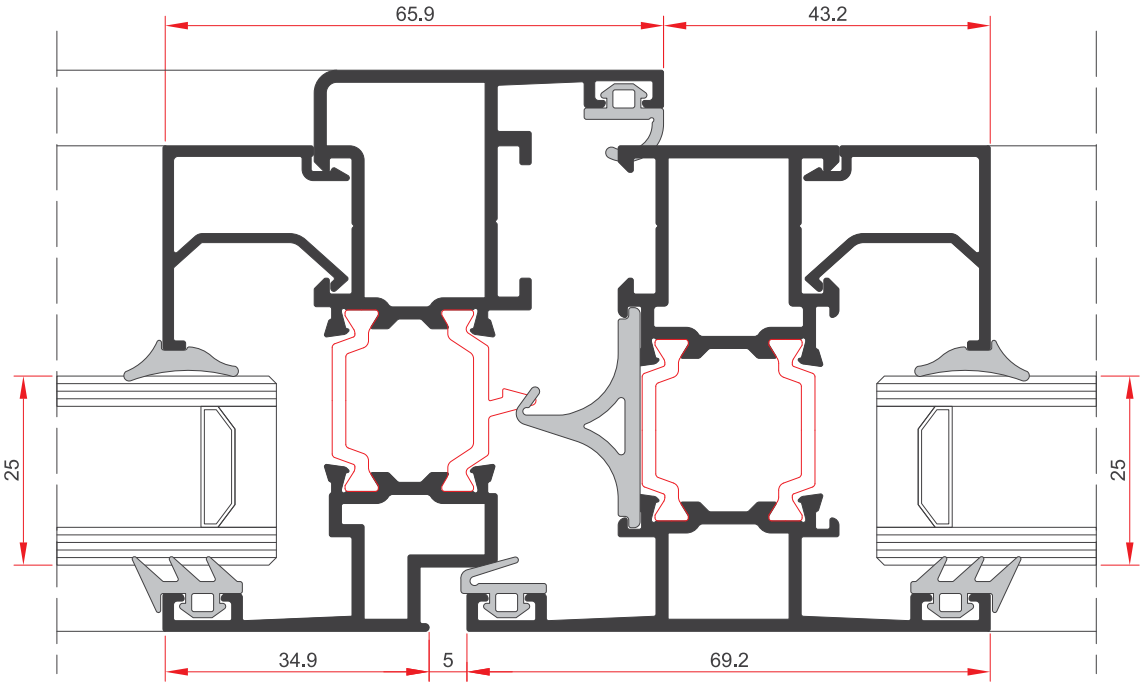

SWT64

DETAYLAR
DETAILS

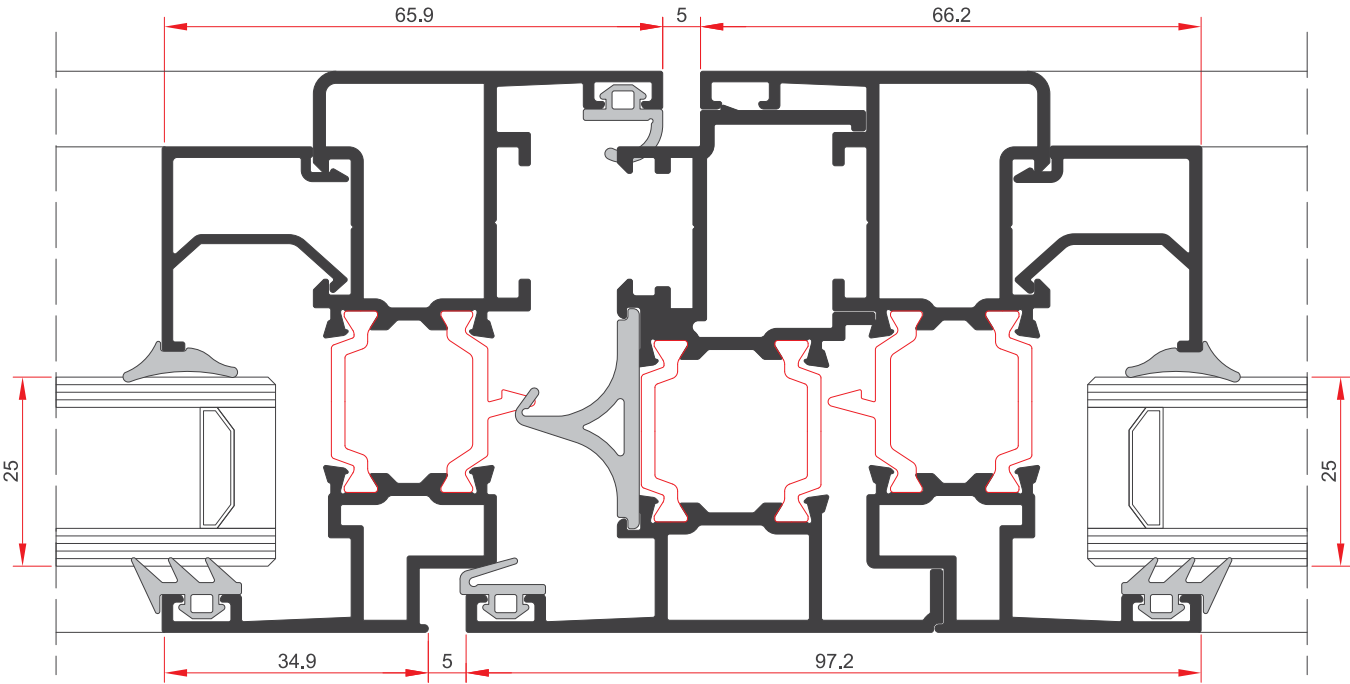

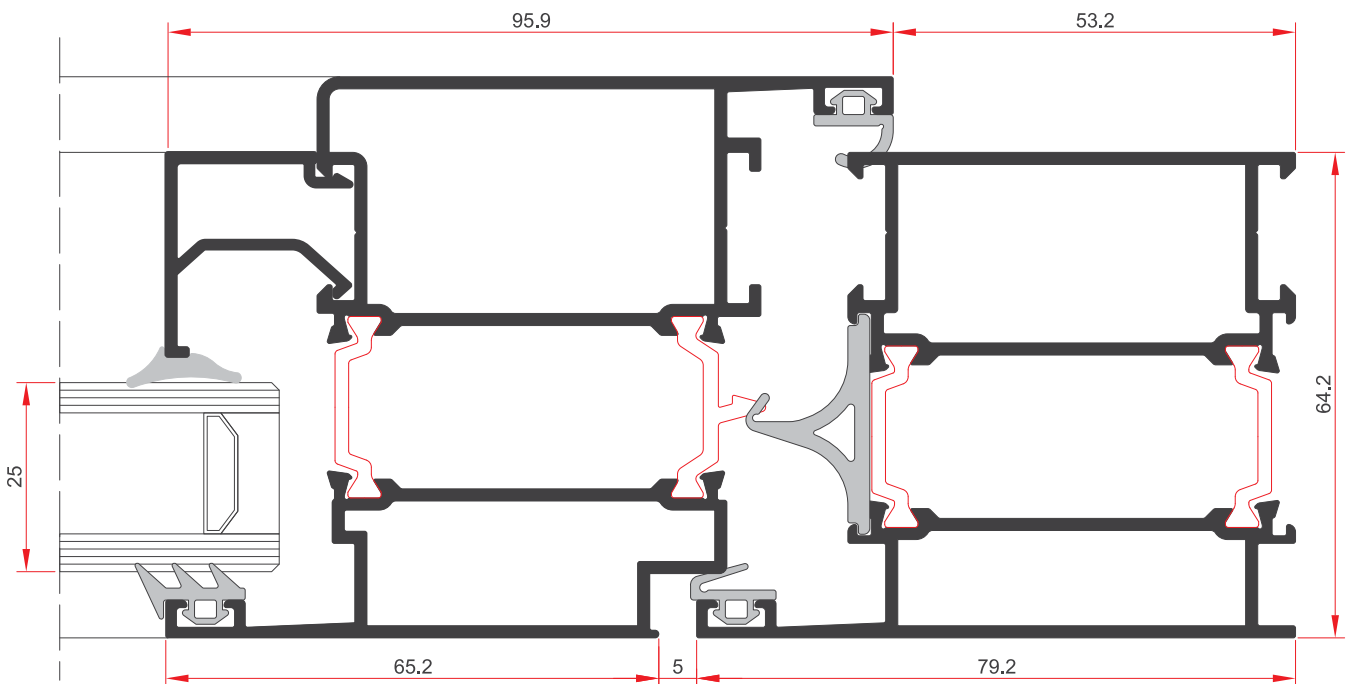
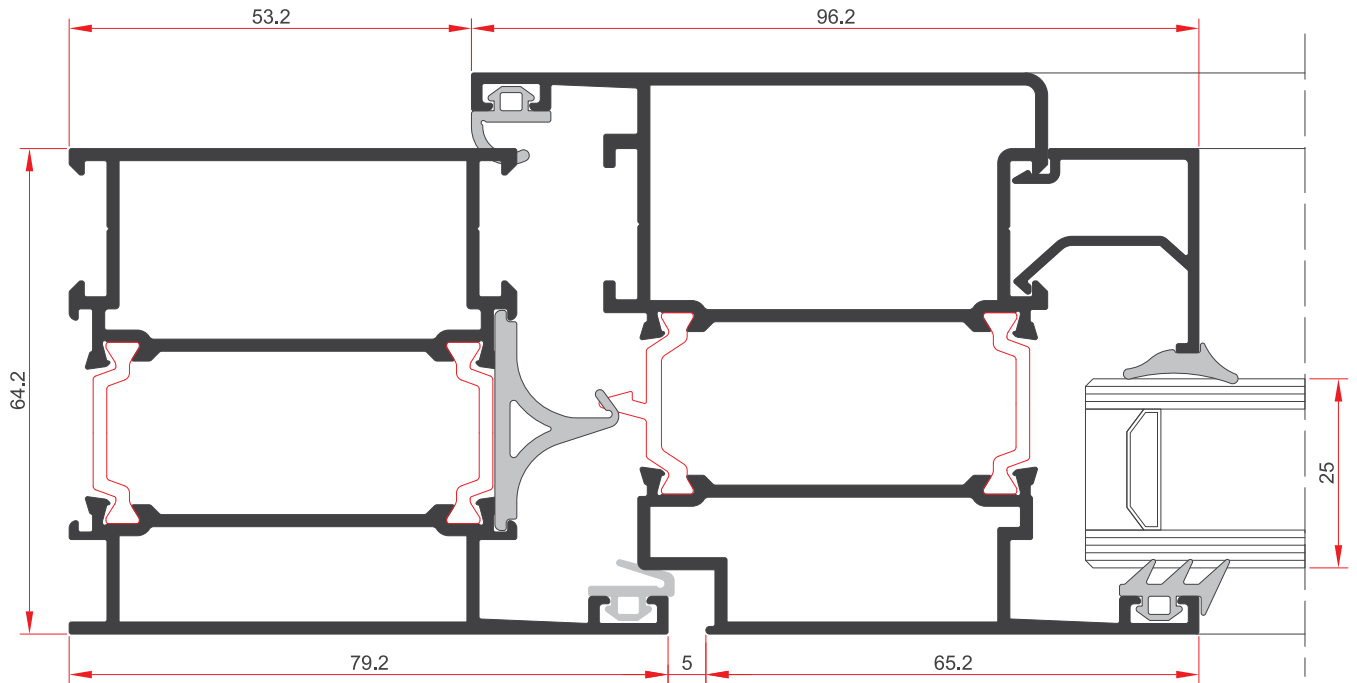

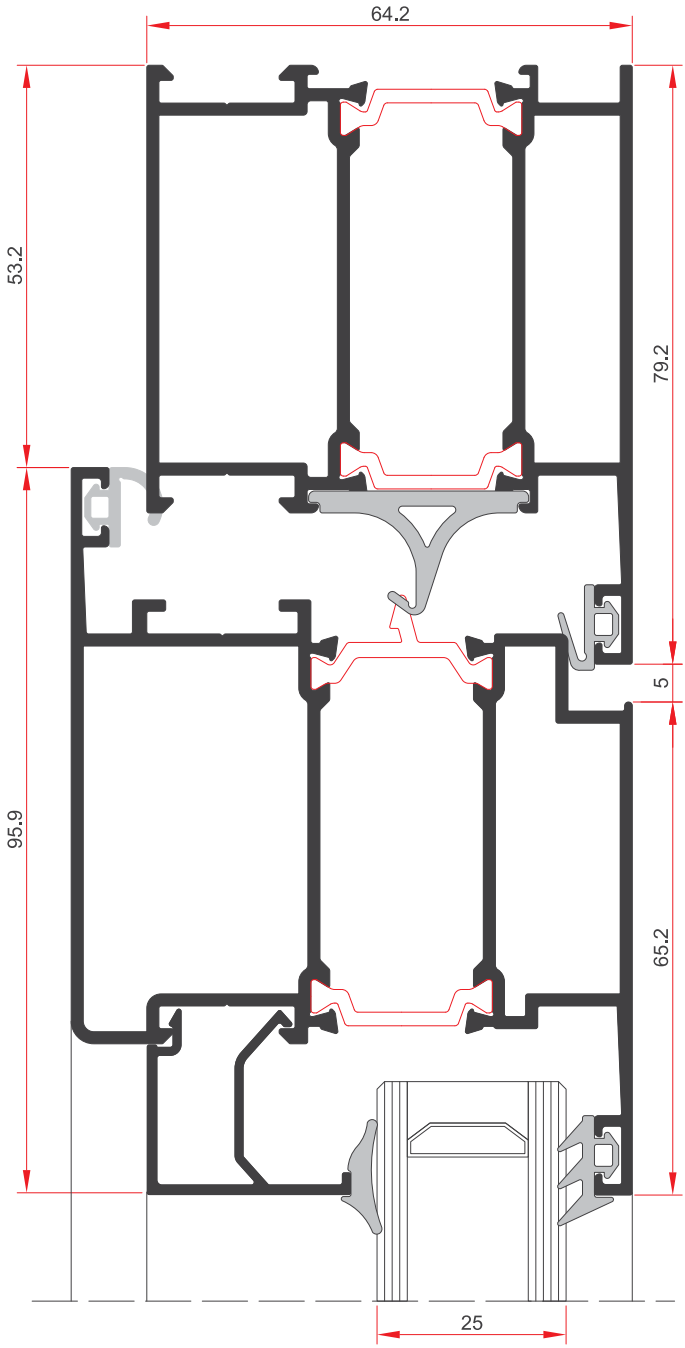

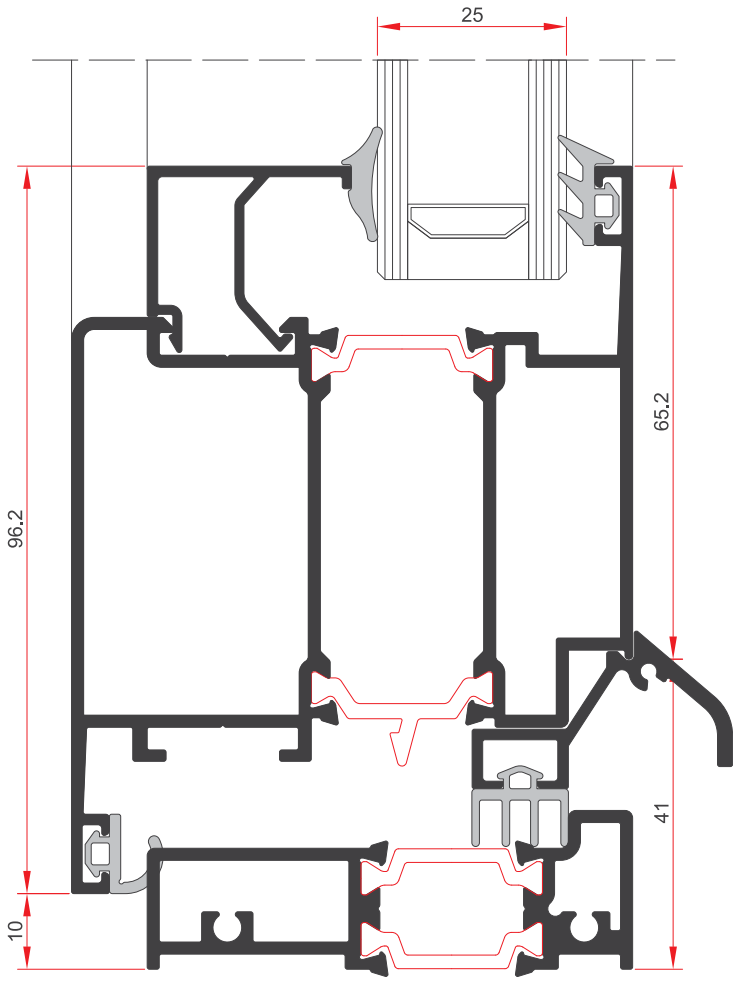

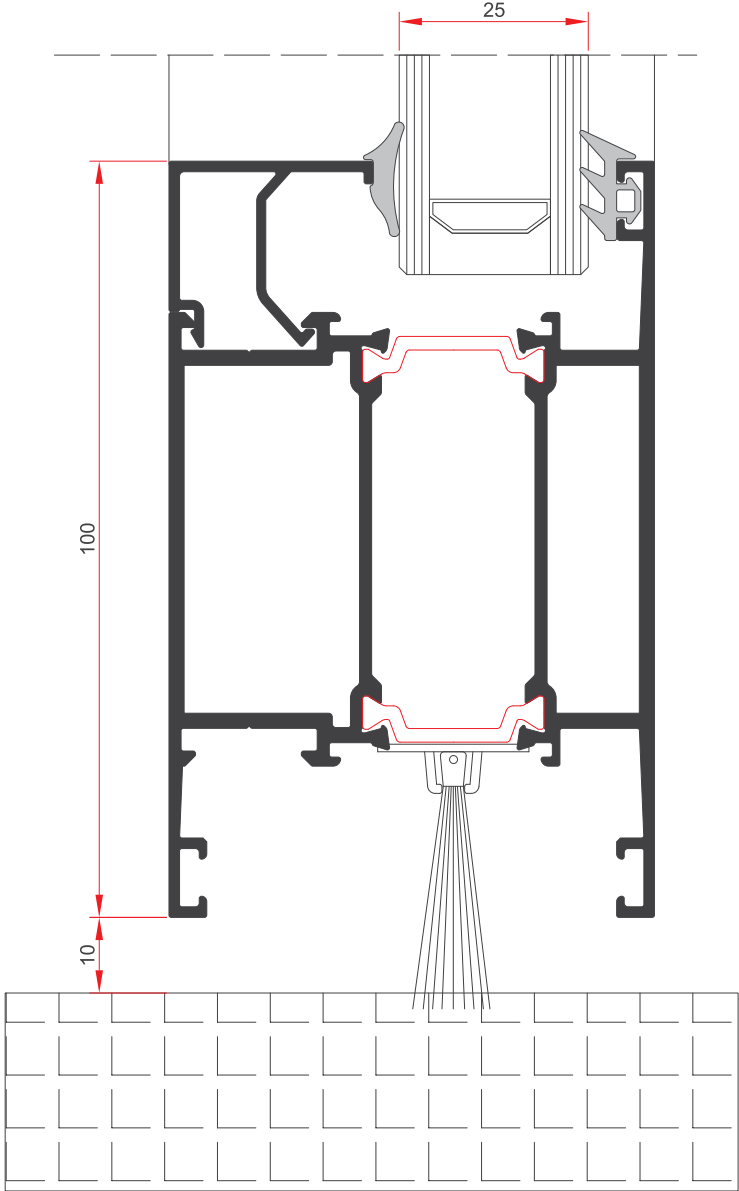

SWT64

DETAYLAR
DETAILS

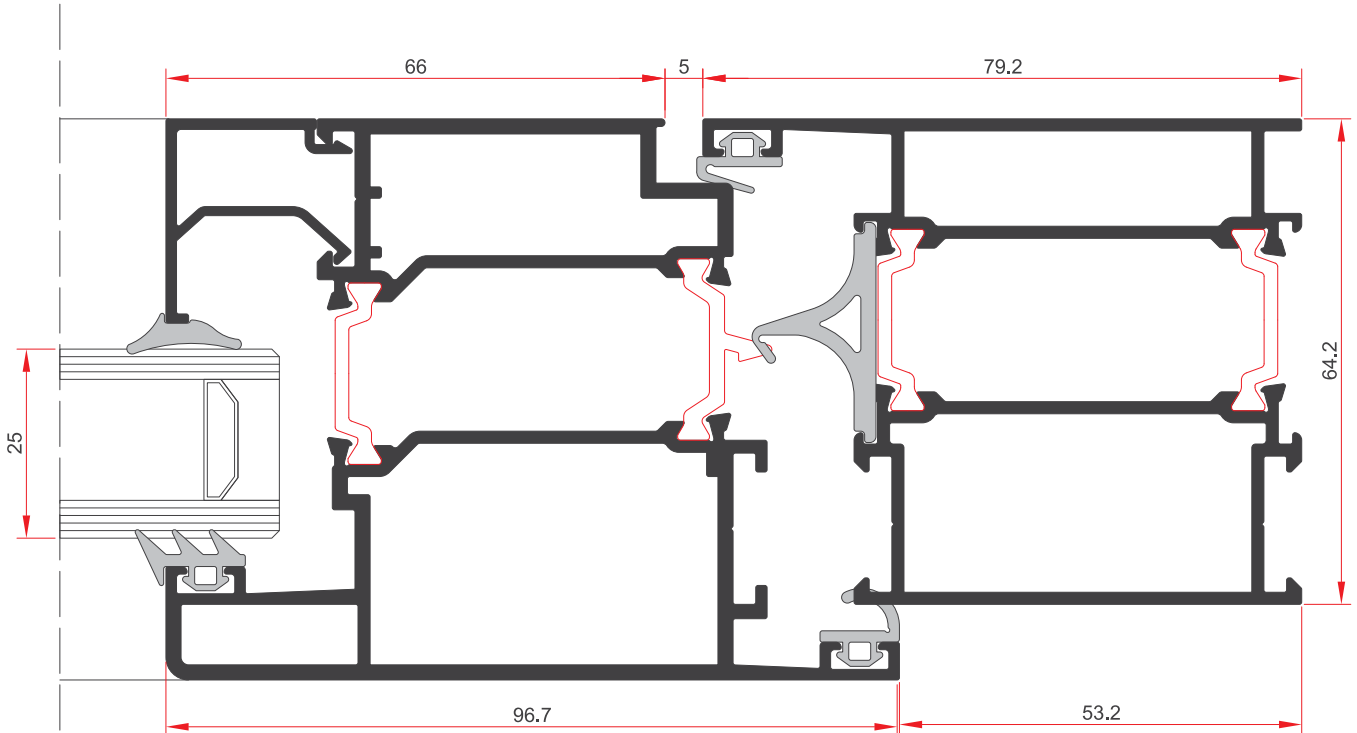
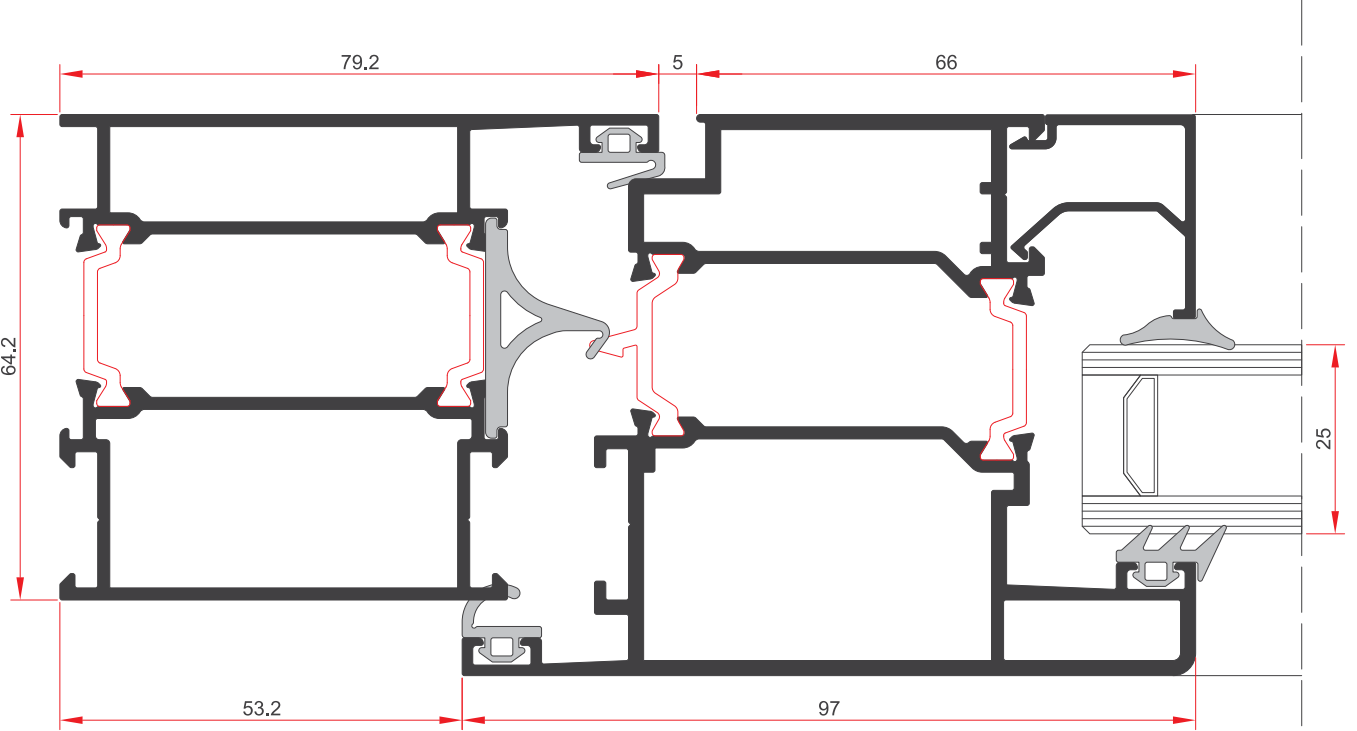

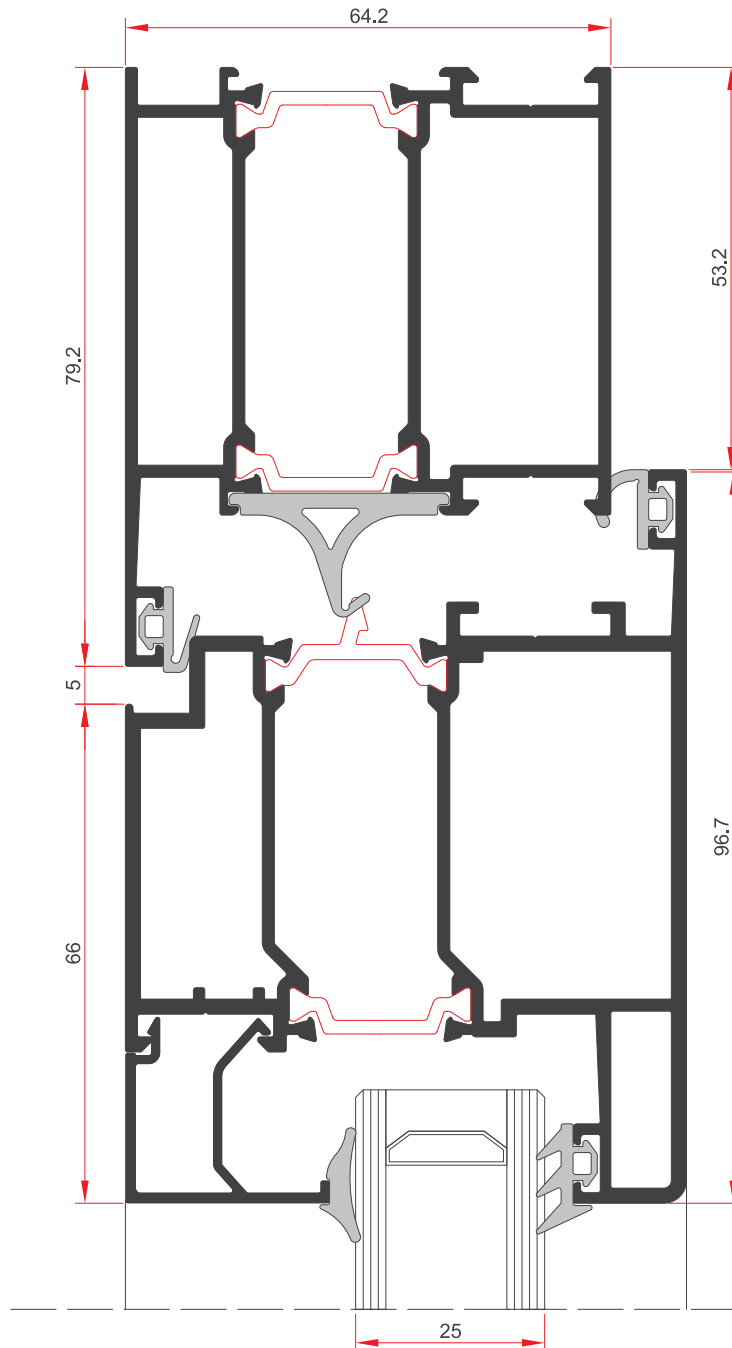

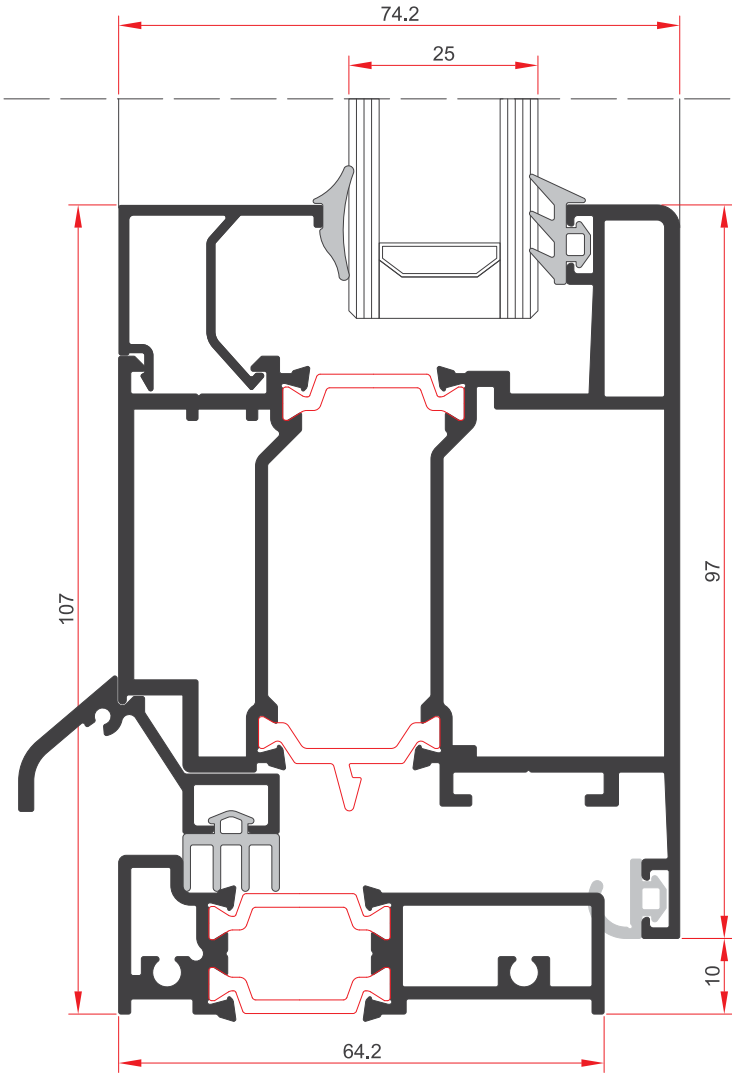

SWT64

DETAYLAR
DETAILS

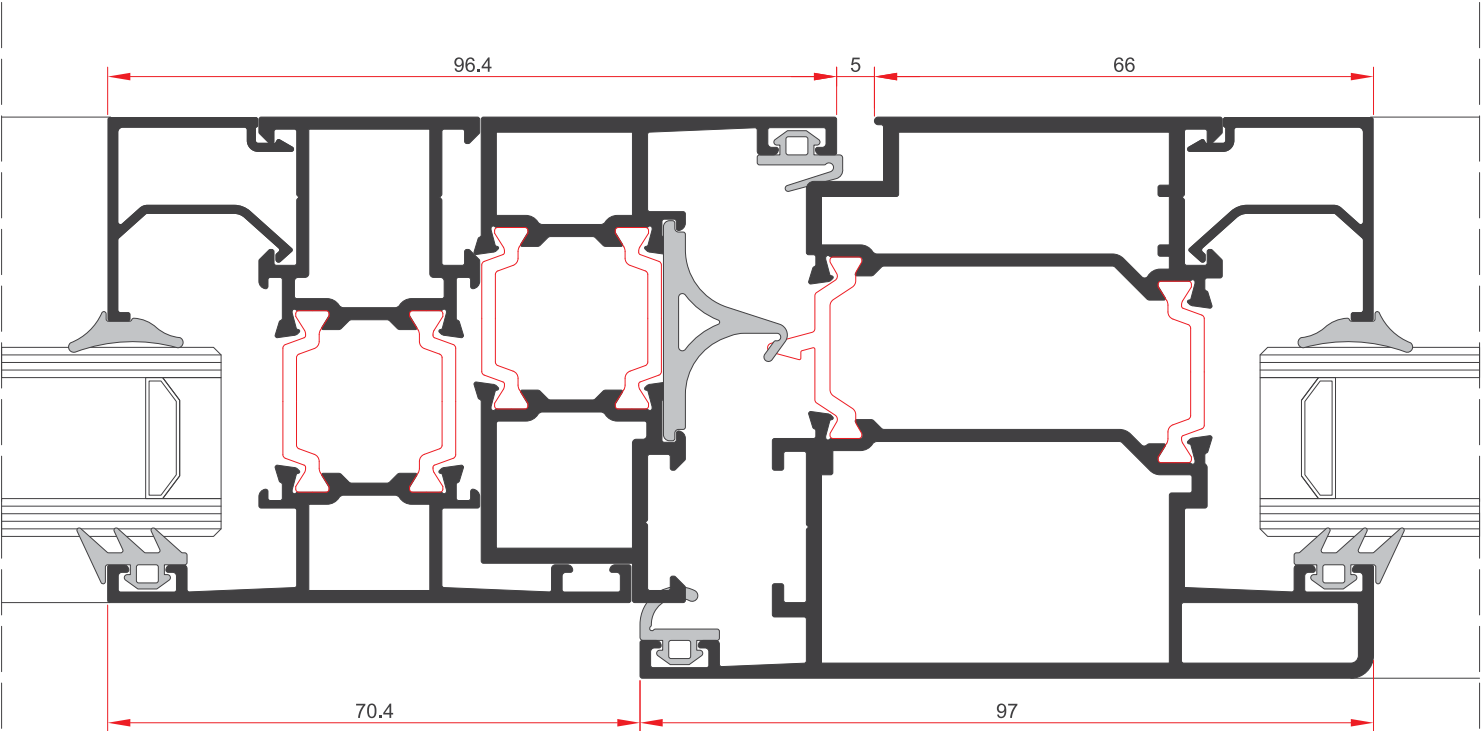
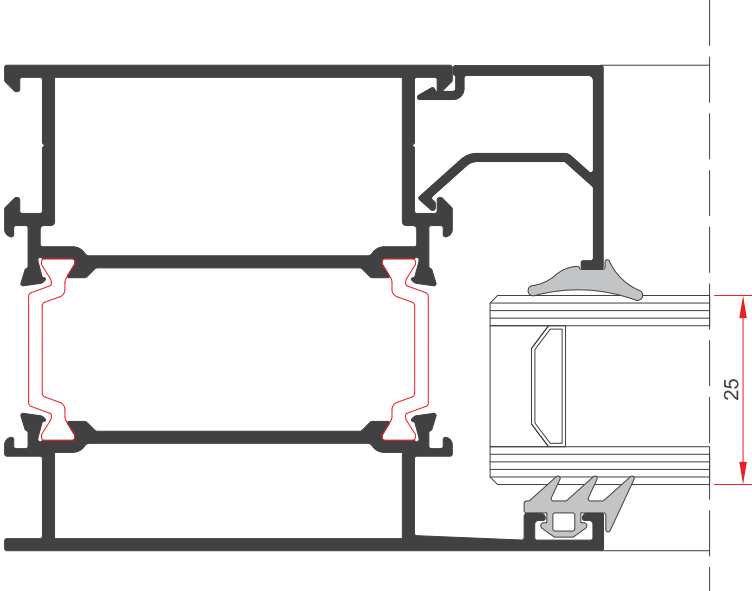

SWT64

DETAYLAR
DETAILS

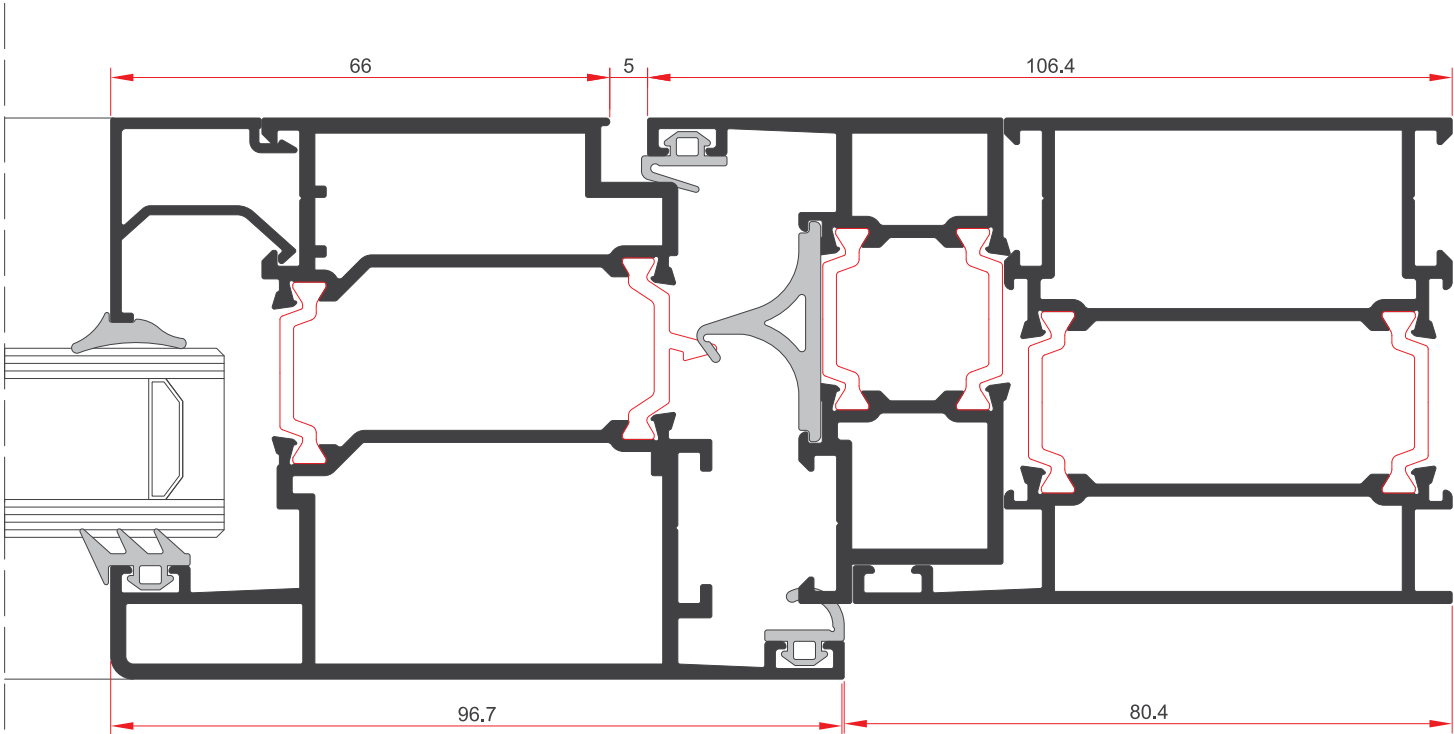

SWT64

DETAYLAR
DETAILS

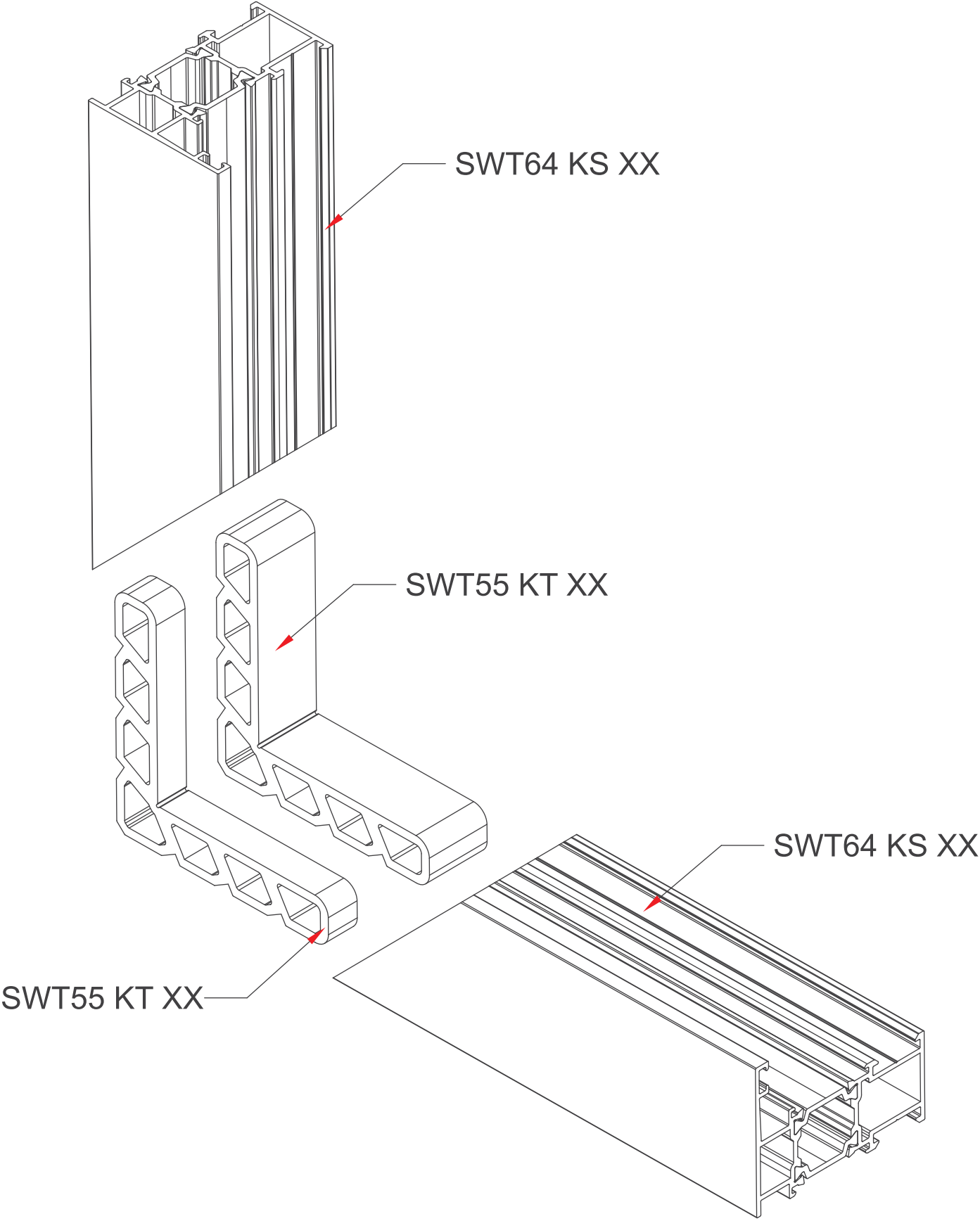

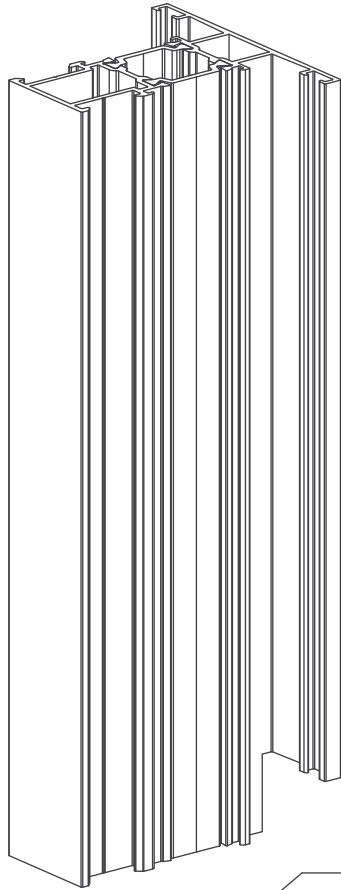

SWT55 KB 02

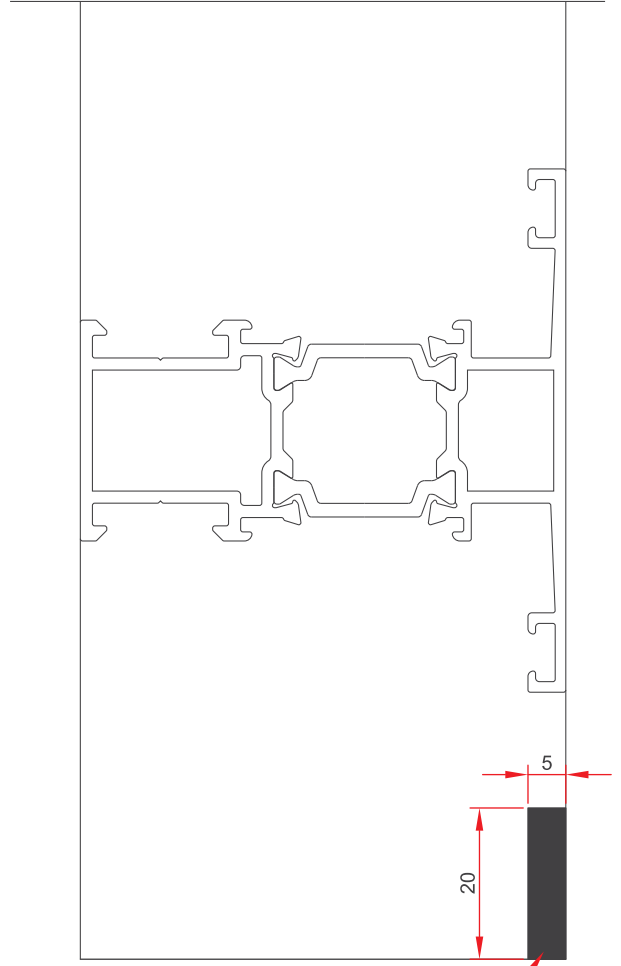

KERTME

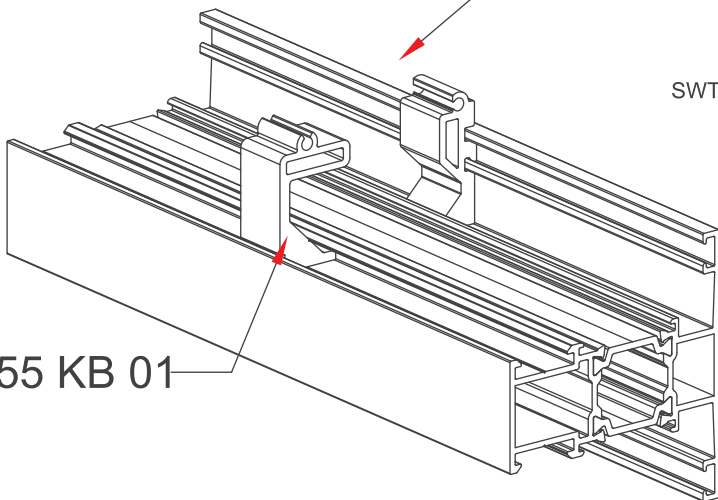

SWT55 KB 01

SWT55 KB 01

SWT55 KB 02

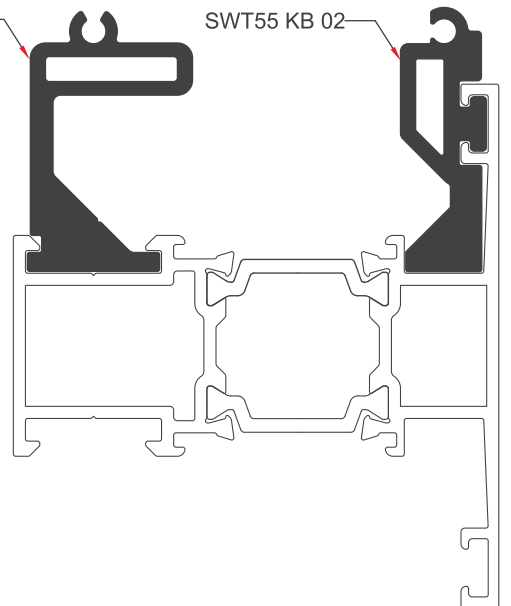

MiMARI KATALOG

ARCHITECTURAL CATALOGUE

Aluminyum Kapı Pencere ve Giydirme Cephe Sistemleri
Aluminium Window Doors and Facade Systems



ALUSYSTEMS
Profil Detayları
ALUSYSTEMS
Profile Details

SWT 64

AKSESUARLAR
ACCESSORIES

ALUSYSTEMS



Aluminyum Kapı Pencere ve Giydirme Cephe Sistemleri
Aluminium Window Doors and Facade Systems





FITIL001		<p>DIŐ CAM FİTİLİ GLAZING GASKET (OUTSIDE)</p> <p>Malzeme/ Material : EPDM Ađırlık/ Weight : 61 gr/m Paket/ Package: 245 m / 15 ğ</p>	
FITIL002		<p>DIŐ BİNİ FİTİLİ SEALING GASKET (OUTSIDE)</p> <p>Malzeme/ Material : EPDM Ađırlık/ Weight : 40 gr/m Paket/ Package: 375 m / 15 ğ</p>	
FITIL003		<p>İÇ BİNİ FİTİLİ SEALING GASKET (INSIDE)</p> <p>Malzeme/ Material : EPDM Ađırlık/ Weight : 50 gr/m Paket/ Package: 300 m / 15 ğ</p>	
FITIL004		<p>KAMA FİTİLİ GLAZING GASKET (INSIDE)</p> <p>Malzeme/ Material : EPDM Ađırlık/ Weight : 46 gr/m Paket/ Package: 326 m / 15 ğ</p>	
FITIL005		<p>KAMA FİTİLİ GLAZING GASKET (INSIDE)</p> <p>Malzeme/ Material : EPDM Ađırlık/ Weight : 56 gr/m Paket/ Package: 268 m / 15 ğ</p>	

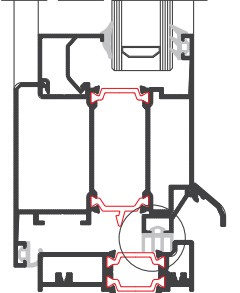

FITIL007		<p>EŞİK FİTİLİ THRESHOLD GASKET</p> <p>Malzeme/ Material : EPDM Ağırlık/ Weight : 66 gr/m Paket/ Package: 227 m / 15 kg</p>	
FITIL008		<p>TOZLUK FİTİLİ CENTRAL GASKET</p> <p>Malzeme/ Material : EPDM Ağırlık/ Weight : 163 gr/m Paket/ Package: 92 m / 15 kg</p>	